COM PAR^I

ITALIAN DESIGN

COM.P.AR è impegnata, dal 1984, a creare e definire una gamma di prodotti per la casa e gli spazi collettivi, caratterizzati da un proprio e riconoscibile design contemporaneo. L'alta affidabilità e la qualità, garantite dalla certificazione ISO 9001, particolarizzano una ricerca progettuale strutturata su processi mirati a tutelare e valorizzare prodotti totalmente Made in Italy. L'attenzione specifica del brand COM.P.AR alla costruzione di una propria identità di prodotto, è condizione di primaria importanza nel panorama europeo ed internazionale. Un'identità che si fonda sempre più sulla scelta di materiali e lavorazioni sostenibili e si esprime attraverso un gusto ricercato ma lineare, proponendo oggetti che vogliono essere un ponte tra l'esperienza e le nuove tecnologie produttive, un dialogo tra la memoria del design e le diverse future tendenze di stile. Le Collezioni di complementi d'arredo qui presentate sono un nuovo punto di partenza per la nostra équipe, nell'intento di dare un preciso strumento di lavoro e risposte sempre più puntuali ai nostri fidati partner commerciali.

COM.P.AR est active, depuis, 1984 dans la création et définition d'une gamme de produits pour l'habitat et la collectivité, caractérisés par leur propre design contemporain bien reconnaissable. La haute fiabilité et la qualité, assurées par la certification ISO 9001 sont caractéristiques d'une recherche de projet structurée sur des processus visant à protéger et valoriser des produits entièrement «Made in Italy». L'attention spécifique du brand COM.P.AR à la construction de sa propre identité de produit est une condition de primaire importance dans le contexte européen et international. Une identité qui se base de plus en plus sur le choix de matériaux et traitements soutenable et qui s'exprime à travers un goût recherché mais linéaire, en proposant des objets qui entendent être un pont entre l'expérience et les nouvelles technologies de production, un dialogue entre la mémoire du design et les différentes tendances futures de style. Les Collections de meubles de complément présentées ici constituent un nouveau point de départ pour notre équipe, dans le but d'offrir un outil de travail précis et de réponses de plus en plus ponctuelles à nos fidèles partenaires commerciaux.

COM.P.AR is committed, since 1984, to create and define a range of products for the home and collective spaces, characterized by their own recognizable contemporary design. The high reliability and quality, guaranteed by the ISO 9001 certification, highlight a structured research project focused on processes aimed at protecting and enhancing products totally Made in Italy. The specific attention of the COM.P.AR brand to the construction of its own product identity is a condition of primary importance in the European and international context. An identity that relies more and more on the choice of sustainable materials and treatments, and finds its expression in a refined but straightforward taste, while proposing objects intended to be a bridge between experience and new production technologies, a dialogue between the memory of design and the different future trends of style. The Collections of furnishing accessories hereby presented are a new starting point for our team, aiming at providing our valuable commercial partners with a precise work instrument and more and more punctual answers.

| INDEX

COLLECTION_2021

TAVOLI

| TABLES
TABLES

Amon table
page 48

Arpa table
page 12

Arpa Extensible table
page 20

Birdy Snack table
page 70

Esse table
page 34

Esse Extensible table
page 26

Esse Round table
page 36

Frau table
page 64

Keram table
page 66

Mango table
page 68

Moà table
page 42

Oblique table
page 52

Origami table
page 06

Plus table
page 56

Zed table
page 60

DIMENSIONI / DIMENSIONES / DIMENSIONS
page 72

TAVOLINI TRASFORMABILI

| TABLES RELEVABLES
TRANSFORMING COFFEE TABLES

Paris table
page 78

Play table
page 82

Simple Round table
page 86

DIMENSIONI / DIMENSIONES / DIMENSIONS
page 90

SEDIE, POLTRONCINE, SGABELLI

| CHAISES, FAUTEUILS, TABOURETS
CHAIRS, ARMCHAIRS, STOOLS

Clery chair
page 162

Desire armchair
page 188

Desy armchair
page 192

Fenice armchair
page 154

Fenice stool
page 158

Flora chair
page 182

Form stool
page 200

Jane Fix armchair
page 190

Jolly armchair
page 122

Jolly chair
page 114

Jolly stool
page 130

Jolly Cross Soft armchair
page 128

Jolly Soft armchair
page 124

Jolly Soft chair
page 118

Liza armchair
page 184

Luxi chair
page 172

Luxi stool
page 174

Mary chair
page 180

Marilyn chair
page 176

Maya chair
page 134

Maya Wood chair
page 132

Mila armchair
page 167

Mila chair
page 166

Mila stool
page 168

Minnie chair
page 100

Minnie Fix stool
page 110

Minnie Soft armchair
page 104

Minnie Swivel Soft armchair
page 106

Momo stool
page 202

Monika chair
page 170

Polly chair
page 138

Polly Wood armchair
page 146

Polly Wood chair
page 140

Polly Wood stool
page 150

Romy stool
page 196

Rosa chair
page 164

Rosy armchair
page 186

Slim chair
page 178

Yoshi chair
page 96

Yoshi Wood chair
page 94

Yumi stool
page 198

DIMENSIONI / DIMENSIONES / DIMENSIONS
page 204

MADIE

| __BUFFETS
__SIDEBOARDS

__Athena sideboard
page 222

__Dama sideboard
page 210

__Ermes sideboard
page 218

__Optik sideboard
page 228

__Vanity sideboard
page 236

DIMENSIONI / DIMENSIONES / DIMENSIONS
page 242

TAVOLINI

| __TABLE BASSE
__COFFEE TABLES

__Billy coffee table
page 266

__Billy Lamp coffee table
page 268

__Birdy coffee table
page 260

__Boat coffee table
page 270

__Club coffee table
page 254

__Cross coffee table
page 256

__Rio coffee table
page 250

__Smart coffee table
page 262

__Square coffee table
page 258

__Tablet coffee table
page 272

__Trendy coffee table
page 246

DIMENSIONI / DIMENSIONES / DIMENSIONS
page 274

CONSOLLE E SCRITTOIO

| __CONSOLES ET BUREAU
__CONSOLE AND WRITING DESK

__Pad console
page 286

__Reverse console
page 280

__Zed console
page 284

DIMENSIONI / DIMENSIONES / DIMENSIONS
page 290

SPECCHIERE

| __MIROIRS
__MIRRORS

__Florence mirror
page 304

__Glory mirror
page 298

__Luxor mirror
page 294

DIMENSIONI / DIMENSIONES / DIMENSIONS
page 306

LIBRERIE

| __BIBLIOTHÈQUES
__BOOKCASES

__Infinity bookcase
page 310

__Plane bookcase
page 318

__Step bookcase
page 314

DIMENSIONI / DIMENSIONES / DIMENSIONS
page 322

ACCESSORI

| __ACCESSOIRES
__ACCESSORIES

__Charlie valet stand
page 326

__Kari clothes stand
page 330

__Ombo umbrella stand
page 332

__Shark clothes stand
page 331

__Snake magazine rack
page 333

DIMENSIONI / DIMENSIONES / DIMENSIONS
page 334

—

TABLES
/ TABLES

| Origami

table

Il tavolo Origami sorprende con le sue forme inaspettate: il piano in ceramica Emperador in finitura opaca, definito da dolci linee curve, è sostenuto dalla base in metallo con i suoi spigoli perfetti e decisi. Il leggero equilibrio che ne scaturisce conferisce una grande eleganza all'ambiente.

design_ **Riccardo Buscato**

La table Origami surprend avec ses formes inattendues: le plateau en céramique Emperador matte, caractérisé par des lignes douces et courbes, est placé sur un piètement en métal aux formes parfaites et bien définies. Le léger équilibre final donne une grande élégance à l'environnement.

Origami table astonishes with its unexpected shapes: the ceramic Emperador top with matt finish is defined by sweet, curved lines and it is sustained by a metal base with precise edges. The light equilibrium that arises from this combination confers the environment elegance.



Base / Piètement / Base: verniciato, verni, coated - Grafite gofrato M11
Piano / Plateau / Top: ceramica, céramique, ceramic - Emperador Opaco K20

TABLES / TABLES
TAVOLI



| Origami_table





Sedia POLLY WOOD

Gambe / Pieds / Legs: legno massiccio, bois massif, solid wood - Frassino canaletto W60

Seduta / Assise / Seat: ecopelle, eco-cuir, eco-leather - Testa di moro EB57

| Origami_table



TABLES / TABLES
TAVOLI



Sedia POLLY WOOD

Gambe / Pieds / Legs: legno massiccio, bois massif, solid wood - Frassino canaletto W60

Seduta / Assise / Seat: ecopelle, eco-cuir, eco-leather - Zenzero EB59



Arpa table

design_Andrea Lucatello

Tavolo dalle linee sinuose ed ancestrali costituito da una serie di corde in metallo d'ineguale lunghezza, tese secondo una regolare interazione tra la base e il piano di cristallo, che esprimono tutta la sua musicalità ed eleganza.

Table aux lignes sinueuses et ancestrales consistant en une série de cordes métalliques de longueurs inégales, tendues selon une interaction régulière entre la base et le plateau verre, qui expriment toute sa musicalité et son élégance.

Table with sinuous and ancestral lines consisting of a series of unequal length metal strings, stretched according to a regular interaction between the base and the glass top, which express all its musicality and elegance.



Base / Piétement / Base: verniciato, verni, coated - Grafite goffrato M11
Piano / Plateau / Top: vetro, verre, glass - Trasparente extrachiaro G07

TABLES / TABLES
TAVOLI





Sedia MAYA

Gambe / Pieds / Legs: verniciato, verni, coated - Grafite goffrato M11

Seduta / Assise / Seat: velluto, velours, velvet - Khaki VL87







TABLES / TABLES
TAVOLI





| Arpa

Extensible table

Il tavolo Arpa in versione allungabile, è qui rappresentato con piano in ceramica. Le due allunghe riposte sottopiano, consentono di aumentare i posti a sedere, prolungando la forma a botte.

design_ **Andrea Lucatello**

La table Arpa Extensible est ici en version céramique. Les deux rallonges sous le plateau permettent de rajouter de la place à table, en étendant sa forme tonneau.

Arpa table in its extendable version is here represented with a ceramic top. The extensions that lie under the top allow to increase the seats, lengthening the barrel shape.



*Base / Piétement / Base: verniciato, verni, coated - Grafite goffrato M11
Piano / Plateau / Top: ceramica, céramique, ceramic - Pietra di Savoia Perla K12*

TABLES / TABLES
TAVOLI



| Arpa Extensible_table





Sedia MARILYN

Gambe e seduta / Pieds et assise / Legs and seat: ecopelle, eco-cuir, eco-leather - Cannella EB44

| Arpa Extensible_table





TABLES / TABLES
TAVOLI

Esse

Extensible table

Il tavolo Esse allungabile è un tavolo dinamico e altamente innovativo per estetica e funzionalità. Un ponte immaginario per realizzare un tavolo da sogno. Un oggetto scultoreo che si esprime attraverso una struttura che si intreccia come dita di una mano per sostenere con leggerezza il piano qui rappresentato in bianco statuario venato accompagnandone il movimento. Versatile ed esclusivo, ideale per accogliere ospiti inattesi con il massimo confort.

design_Andrea Lucatello

La table Esse Extensible est une table dynamique et hautement innovante par son esthétique et fonctionnalité. Une sorte de pont imaginaire pour réaliser une table de rêve. Un objet sculptural qui s'exprime à travers une structure qui s'entrelace comme des doigts d'une main pour soutenir avec légèreté un plateau en céramique blanche veinée accompagnant le mouvement. Versatile et exclusif, idéal pour recevoir des invités à surprise en leur offrant un maximum de confort.

The Esse Extensible is a dynamic and highly innovative table in the field of aesthetics and functionality. It is an imaginary bridge able to realize a dream table. It is like a sculptural object that expresses himself through a structure that intertwines as the fingers of a hand to support a veined white ceramic top with airiness following its movement. Exclusive and versatile, it is ideal to welcome unexpected guests with the maximum comfort.



Base / Piétement / Base: verniciato, verni, coated - Titanio + bronzo metallizzato U01
Piano / Plateau / Top: ceramica, céramique, ceramic - Bianco Statuario Venato Lucido K05

TABLES / TABLES
TAVOLI



| Esse Extensible_table





TABLES / TABLES
TAVOLI

| Esse Extensible_table







TABLES / TABLES
TAVOLI



Sedia POLLY WOOD

Gambe / Pieds / Legs: legno massiccio, bois massif, solid wood - Frassino canaletto W60

Seduta / Assise / Seat: tessuto, tissu, fabric Karina - Testa di moro TK06

Schienale / Dossier / Backrest: tessuto, tissu, fabric Karina - Bianco TK01

| Esse table

Il tavolo Esse in versione fissa è la soluzione per ogni stile d'arredo. Con le molteplici finiture del piano, dal vetro alla ceramica, abbinata ai verniciati della base, costituisce un prezioso alleato nella definizione del carattere della casa. Per meglio rispondere alle esigenze di spazio, Esse è disponibile in due diverse misure del piano.

design **Andrea Lucatello**

La table Esse dans sa version fixe est la solution pour chaque style d'ameublement. Avec les différentes finitions du plateau, du verre à la céramique, coordonnées à les couleur du piètement, cette table est un élément essentiel de la personnalité de la maison. Pour mieux répondre aux exigences de place, Esse est disponible dans deux possibles dimensions.

Esse table in its fixed version is the solution for every furnishing style. With the varied finishes of the top, from glass to ceramic, paired with the coating of the base it constitutes a precious allied in the definition of the character of the house. To better respond to space needs, Esse is available in two different measures of the top.



Base / Piètement / Base: verniciato, verni, coated - Titanio + bronzo metallizzato U01
Piano / Plateau / Top: ceramica, céramique, ceramic - Calacatta Gold Lucido K13

TABLES / TABLES
TAVOLI



Tavolo ESSE

Base / Piétement / Base: verniciato, verni, coated - Titanio + bronzo metallizzato U01

Piano / Profile / Plateau / Top: vetro, verre, glass - Trasparente extrachiaro G07

Sedia JOLLY

Gambe e seduta / Pieds et assise / Legs and seat: tessuto, tissu, fabric Karina - Grigio polvere TK03

Profilo / Profile / Piping: ecopelle, eco-cuir, eco-leather - Testa di moro EB57

Esse Round

table

design_Andrea Lucatello

Nella sua versione più piccola il tavolo Esse Round esalta la sua unicità dando vita ad una base che cambia forma a seconda della prospettiva. Il piano in vetro poggia leggero su quattro punti cardinali capaci di calamitare lo sguardo orientando lo spettatore ad apprezzare un'opera assolutamente originale.

Dans la version plus petite la table Esse Round exalte son unicéité donnant naissance à une base qui change de forme selon la perspective. Son plateau s'appuie avec souplesse sur les quatre points cardinaux qui attirent le regard en guidant le spectateur pour qu'il apprécie une œuvre originale.

In its smaller version the Esse table enhances its uniqueness, giving life to a base that changes shape depending on the perspective through which it is observed. Its top rests on four cardinal points capable of transfixing the onlookers making them enjoying an original artwork.



Base / Piétement / Base: verniciato, verni, coated - Bronzo metallizzato U03
Piano / Plateau / Top: vetro, verre, glass - Trasparente extrachiaro G07

TABLES / TABLES
TAVOLI



| Esse Round_table





Sedia JOLLY

Gambe e seduta / Pieds et assise / Legs and seat: tessuto, tissu, fabric Karina - Grigio platino TK24

Profilo / Profile / Piping: ecopelle, eco-cuir, eco-leather - Testa di moro EB57

| Esse Round_table





TABLES / TABLES
TAVOLI

Moà

table

Il tavolo Moà si mostra in tutta la sua maestosa bellezza traendo ispirazione dalla natura. Come una quercia Moà sembra affondare le sue radici nella terra per sorreggere con grande forza il vetro del piano, trasparente ed etereo come un cielo senza nubi.



design_Arter&Citton

La table Moà se montre majestueuse de beauté s'inspirant de la nature. Telle qu'un chêne Moà enfonce ses racines dans la terre pour soutenir avec une grande énergie le verre du plateau, transparent et éthéré come un ciel sans nuages.

Table Moà shows itself in all its majestic beauty by taking inspiration from nature. As an oak, Moà seems to plunge its roots in the land to powerfully hold glass top. Transparent and ethereal like a sky without clouds.

*Base / Piétement / Base: legno impiallacciato, bois placage, veneered wood - Noce canaletto W10
Piano / Plateau / Top: vetro, verre, glass - Trasparente extrachiario G07*

TABLES / TABLES
TAVOLI







Sedia POLLY WOOD

Gambe / Pieds / Legs: legno massiccio, bois massif, solid wood - Frassino canaletto W60

Seduta / Assise / Seat: tessuto, tissu, fabric Karina - Testa di moro TK06

Schienale / Dossier / Backrest: tessuto, tissu, fabric Karina - Bianco TK01





TABLES / TABLES
TAVOLI

Amon

table

L'apparente immobilità del tavolo Amon, dalle forme simmetriche e imponenti, svanisce quando all'occorrenza si apre per aumentare la lunghezza del suo piano in ceramica. Le gambe in legno massiccio scorrono per sostenerlo in tutta la sua lunghezza e dare spazio alla quotidianità.

design **Andrea Lucatello**

L'apparente immobilità de la table Amon, aux formes importantes et symétriques, disparaît quand elle s'ouvre, en étendant la longueur du plateau en céramique. Les pieds en noyer canaletto glissent pour soutenir le plateau dans toute sa longueur et donner de la place à la vie quotidienne.

The apparent immobility of the Amon table, with its symmetric and majestic shapes, disappears when you extend the ceramic top. The ash wood legs flow to sustain the top in its entire length, giving space to everyday life.



Base / Piétement / Base: legno massiccio, bois massif, solid wood - Frassino canaletto W60
Piano / Plateau / Top: ceramica, céramique, ceramic - Noir Desir Lucido K04

TABLES / TAVOLI

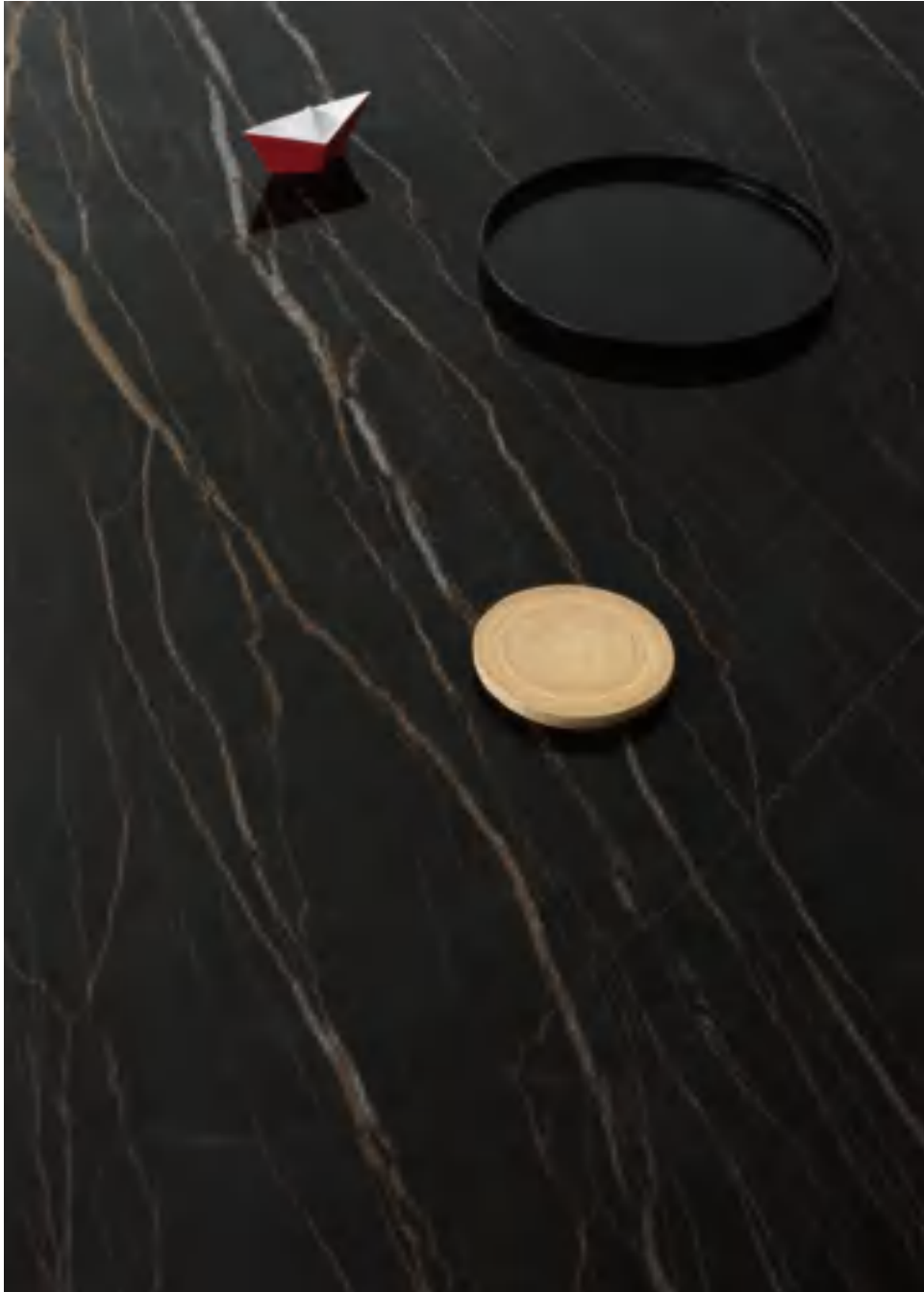

| Amon_table





Sedia FLORA

Gambe / Pieds / Legs: legno massiccio, bois massif, solid wood - Frassino canaletto W60

Seduta / Assise / Seat: ecopelle, eco-cuir, eco-leather - Lino EB27

| Oblique table

Il piano del modello Oblique, allungabile ai due lati, offre un'interessante esperienza tattile, con finiture apprezzabili non solo alla vista: le ceramiche infatti permettono di dare alla superficie una texture piacevole al tatto, oltre che riflessi e sfumature diverse. La base, con il suo andamento inclinato, sostiene il piano mantenendo una posizione centrale.



design_Dario Delpin

Le plateau de la Oblique, extensible dans les deux côtés, donne une sensation agréable au toucher. Avec des finitions magnifiques à la vue, mais pas seulement: les céramiques en effet établissent une texture agréable au toucher et beaucoup de nuances et réflexes.

Le piètement oblique soutient le plateau, en restant toujours au milieu.

Top table of model Oblique offers an interesting tactile experience. The table extends on both sides with finishes admirable not only to the sight: ceramics in fact allow to give the surface not only a pleasant texture but also reflections and hues. The base, with its sloped pace, sustains the top in a central position.

Base / Piètement / Base: legno impiallacciato, bois placage, veneered wood - Noce canaletto W10
Piano / Plateau / Top: ceramica, céramique, ceramic - Oxide Bianco K10

TABLES / TABLES
TAVOLI



Sedia FLORA

Gambe / Pieds / Legs: legno massiccio, bois massif, solid wood - Frassino canaletto W60

Seduta / Assise / Seat: ecopelle, eco-cuir, eco-leather - Lino EB27

| Oblique_table





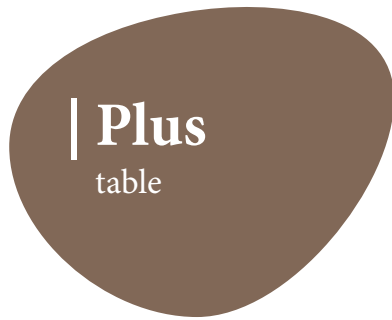

| **Plus**
table

| design_Arter&Citton

Tutta la forza della natura è racchiusa nelle venature della finitura in Noce canaletto presente sia nel piano che nelle gambe del tavolo Plus. Nella versione allungata il meccanismo di scorrimento è visibile sempre nella stessa finitura, per non interrompere il dialogo che lega le gambe al piano in un pezzo d'arredo di grande imponenza.

Toute la force de la nature est contenue dans le veinage de la finition noyer du plateau et du piétement de la table Plus. Dans la version extensible, le mécanisme est toujours dans la même finition, pour ne pas arrêter la liaison entre les pieds et le plateau d'un produit de grande classe.

All the strenght of nature is enclosed in the veins of the walnut finish of both top and legs of table Plus. In its extended version the sliding mechanism is visible always in the same finish in order not to stop the dialogue between the legs and the top, giving birth to a majestic piece of furniture.

Base e piano / Piétement et plateau / Base and top: legno impiallacciato, bois placage, veneered wood - Noce canaletto W10



TABLES / TABLES
TAVOLI



| Plus_table



Sedia MILA

Gambe / Pieds / Legs: legno massiccio, bois massif, solid wood - Noce canaletto

Seduta / Assise / Seat: ecopelle, eco-cuir, eco-leather - Bianco EB01

Retro / Arrière / Back: legno impiallacciato, bois placage, veneered wood - Noce canaletto W10



TABLES / TABLES
TAVOLI

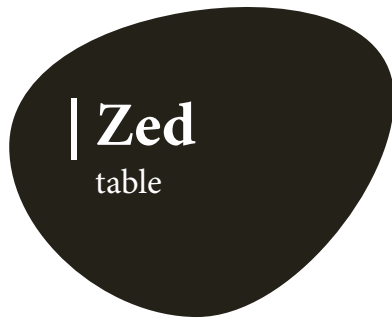

| Zed

table

L'inconfondibile forma a "zeta" del tavolo Zed si caratterizza per l'inserito nella base di un elemento laccato, che fa da trait d'union tra la finitura in Noce canaletto e l'ambiente in cui si trova, per un risultato sempre di grande ricercatezza nello stile e nel design.

design_Andrea Lucatello

L'unique forme à « Z » de la table Zed est caractérisée par un élément laqué, qui est la vraie liaison entre la finition noyer du piétement et l'environnement, pour un résultat toujours de grand style et du design.

The unique "zed" shape of table Zed is characterized by the insert in the base of a lacquered element which is the link between the walnut finish and the environment in which it lies and it is the result of huge care to style and details.

Base / Piétement / Base: legno impiallacciato, bois placage, veneered wood - Noce canaletto W10 / laccato, laqué, lacquered - Bronzo metallizzato L71
Piano / Plateau / Top: legno impiallacciato, bois placage, veneered wood - Noce canaletto W10

TABLES / TABLES
TAVOLI



| Zed_table



Sedia FLORA

Gambe / Pieds / Legs: legno massiccio, bois massif, solid wood - Frassino canaletto W60

Seduta / Assise / Seat: ecopelle, eco-cuir, eco-leather - Cenere EB07



Sedia FLORA

Gambe / Pieds / Legs: legno massiccio, bois massif, solid wood - Frassino canaletto W60

Seduta / Assise / Seat: ecopelle, eco-cuir, eco-leather - Acciaio EB04

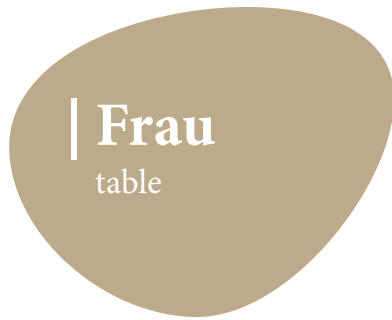

Frau

table

Il tavolo Frau, con il suo piano in vetro abbinato alle gambe laccate, porta luminosità e leggerezza, con la possibilità di allungarsi in entrambi i lati. Quando praticità e bellezza si incontrano, l'effetto è sempre sorprendente.

design_Com.p.ar

La table Frau, avec son plateau en verre assorti aux pieds vernis, donne de la luminosité et de la légèreté, avec la possibilité de s'étendre dans les deux côtés. Lorsque la praticité et la beauté se fondent, l'effet est toujours surprenant.

Frau table with its glass top and lacquered legs gives the space brightness and lightness and has the possibility of extending on both sides. When practicality and beauty encounter the result is always amazing.

Base / Piétement / Base: laccata, laqué, lacquered - Bronzo metallizzato L71
Piano / Plateau / Top: vetro, verre, glass: Trasparente extrachiaro G07

TABLES / TABLES
TAVOLI



Sedia MARILYN

Gambe e seduta / Pieds et assise / Legs and seat: ecopelle, eco-cuir, eco-leather - Giallo EB17

| Keram

table

Il dialogo tra la luce e la materia è evidente nel tavolo Keram: il sottile piano allungabile in ceramica lascia leggere in tutta la sua superficie la bellezza che la luce mette in evidenza. Le gambe altrettanto esili sostengono il tavolo accompagnando il movimento di apertura.

design_Com.p.ar

Le dialogue entre la lumière et la matière est évidente dans la table Keram: le charme du plateau extensible est valorisé par la lumière qui donne de la valeur à la surface en céramique. Les pieds fins soutient la table et accompagnent l'ouverture du plateau.

The dialogue between light and substance is evident in the Keram table: its thin ceramic extendable top leaves a sensation of lightness and beauty in all its surface. The slight legs sustain the top accompany the opening movement.



Base / Piétement / Base: verniciato, verni, coated - Grafite goffrato M11
Piano / Plateau / Top: ceramica, céramique, ceramic - Pietra di Savoia Antracite K11

TABLES / TABLES
TAVOLI



Sedia CLERY

Gambe e schienale / Pieds et dossier / Legs and backrest:
ecopelle, eco-cuir, eco-leather - Acciaio EB04

Seduta / Assise / Seat: ecopelle, eco-cuir, eco-leather - Cenere EB07

Sedia CLERY

Gambe, schienale e seduta /

Pieds, dossier et assise / Legs, backrest and seat:
ecopelle, eco-cuir, eco-leather - Acciaio EB04

| Mango

table

design_Com.p.ar

Il tavolo allungabile Mango ha due elementi d'appoggio a terra fissi. Il contrasto tra la base e il piano è evidente soprattutto nelle finiture. L'etereo spessore del piano in ceramica sembra levitare sopra alla robusta base in metallo.

La table extensible Mango a deux éléments de support. Le contraste entre le piétement et le plateau est évident surtout dans les finitions disponibles. Le mince épaisseur de la céramique donne l'impression que le plateau flotte sur le solide piétement en métal

The extendable table Mango has two fixed supporting elements. The contrast between the top and the base is mostly evident in the base. The heavenly thickness of the ceramic top seems to levitate on the robust metal base.



Base / Piétement / Base: verniciato, verni, coated - Nero goffrato M20

Piano / Plateau / Top: ceramica, céramique, ceramic - Bianco Statuario Venato Lucido K05

TABLES / TABLES
TAVOLI

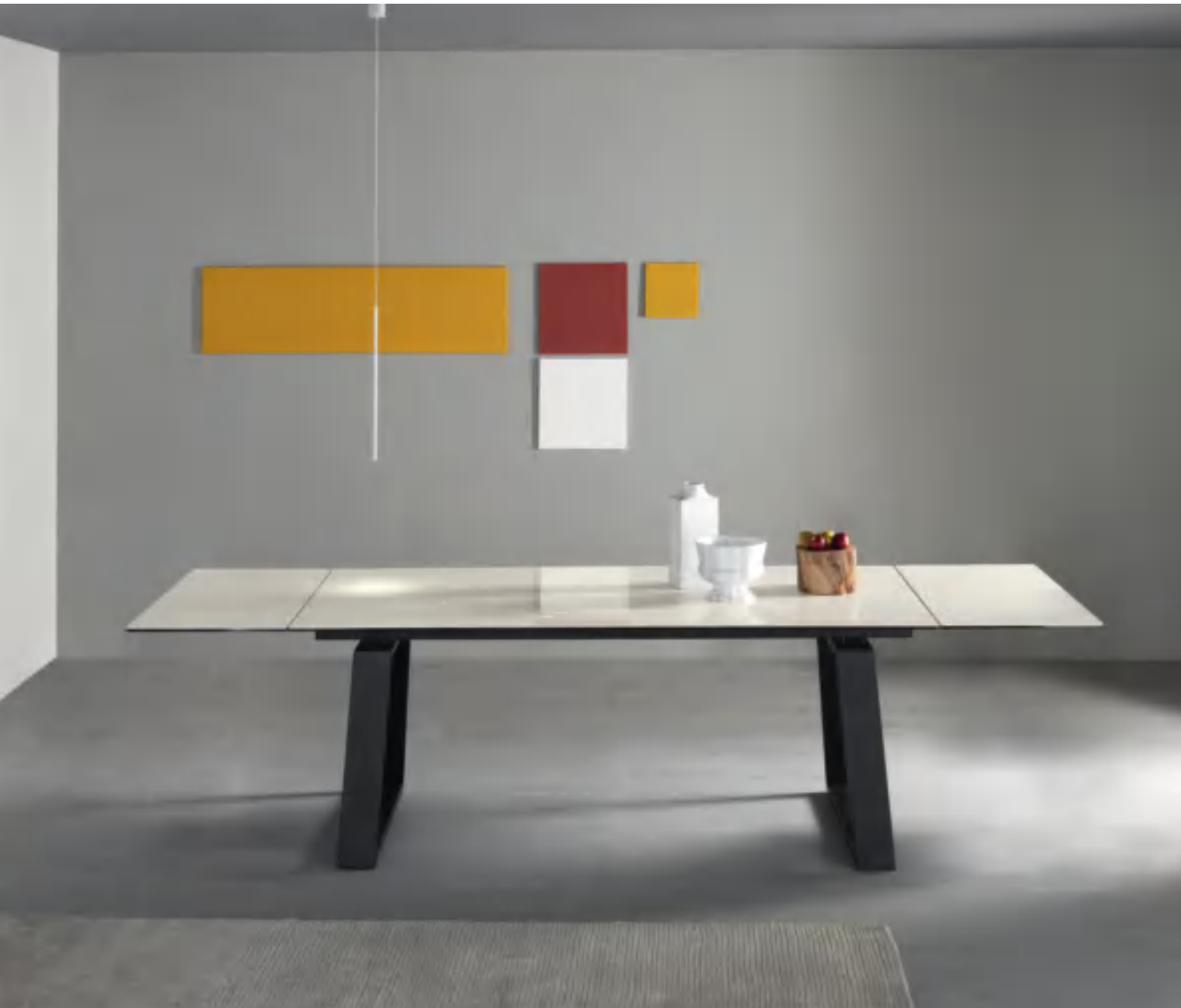

Birdy Snack table

Gli elementi asimmetrici del tavolino Birdy si ripresentano in una versione più alta, per l'utilizzo con sedia o sgabello e con il piano quadrato. Per una sosta rapida dallo spirito vivace.

design_Com.p.ar

Les éléments asymétriques de la table Birdy caractérisent aussi cette version plus haute avec un plateau carré, pour l'utiliser avec des chaises ou des tabourets. Pour une pause vite et dynamique.

The asymmetrical elements of table Birdy are represented in a higher version, to be used with chair or stool and with a squared top. For a rapid stop with a lively spirit.



H.75 / H.90

Base / Piétement / Base: verniciato, verni, coated - Grafite goffrato M11

Piano / Plateau / Top: ceramica, céramique, ceramic - Oxide Nero K09

Sgabello JOLLY

Gambe / Pieds / Legs: legno massiccio, bois massif, solid wood - Frassino fumé W57

Seduta / Assise / Seat: tessuto, tissu, fabric Karina - Verde acido TK09

Profilo / Profile / Piping: ecopelle, eco-cuir, eco-leather - Testa di moro EB57



Poltroncina JOLLY

Gambe / Pieds / Legs: legno massiccio, bois massif, solid wood - Frassino fumé W57

Seduta / Assise / Seat: tessuto, tissu, fabric Karina - Grigio lava TK04, Tortora TK02

Profilo / Profile / Piping: ecopelle, eco-cuir, eco-leather - Testa di moro EB57

| DIMENSIONI
DIMENSIONES
DIMENSIONS

| Tavoli

tables, tables

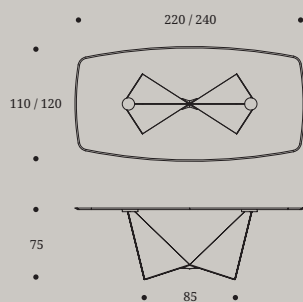

Origami table
page 06

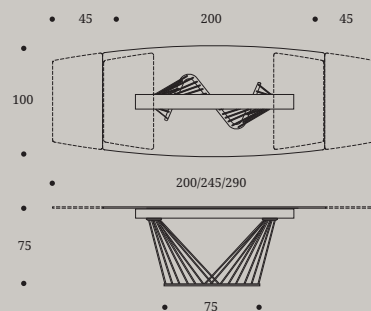

Arpa Extensible table
page 20

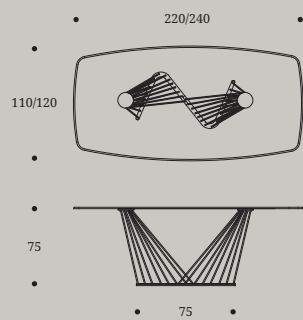

Arpa table
page 12

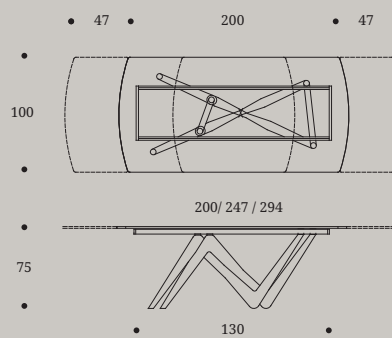

Esse Extensible table
page 26

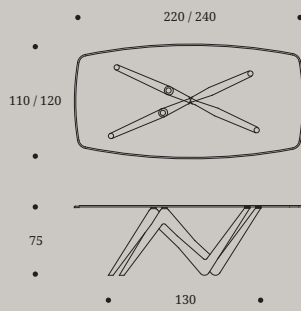

Esse table
page 34

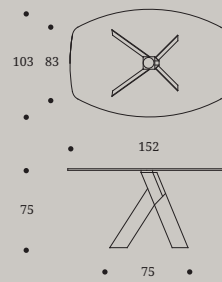

Moà table
page 42

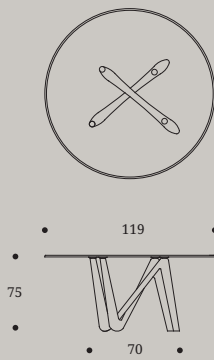

Esse Round table
page 36

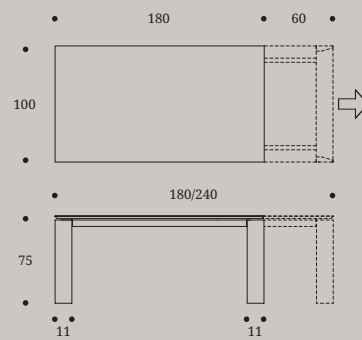

Amon table
page 48

| DIMENSIONI
DIMENSIONES
DIMENSIONS

| Tavoli

tables, tables

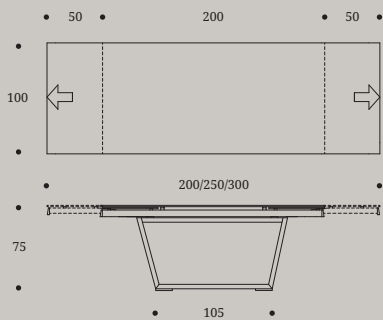

Oblique table
page 52

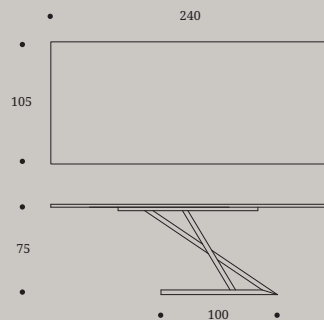

Zed table
page 60

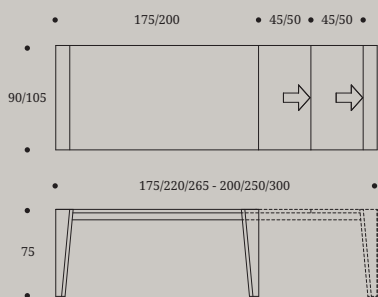

Plus table
page 56

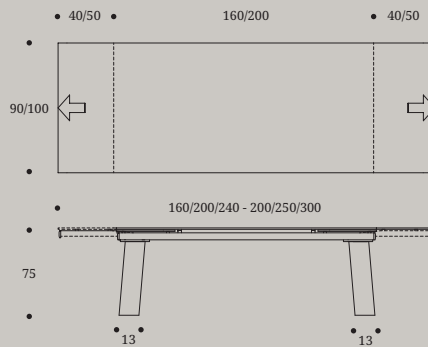

Frau table
page 64

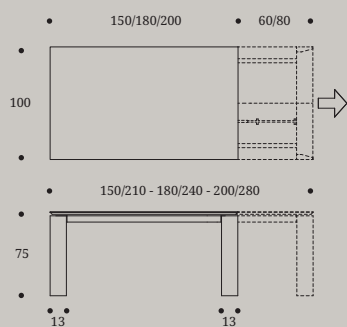

Keram table
page 66

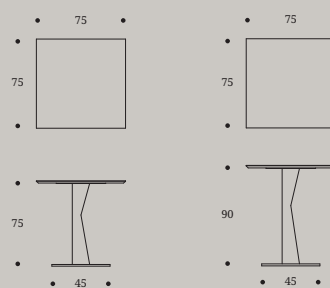

Birdy Snack table
page 70

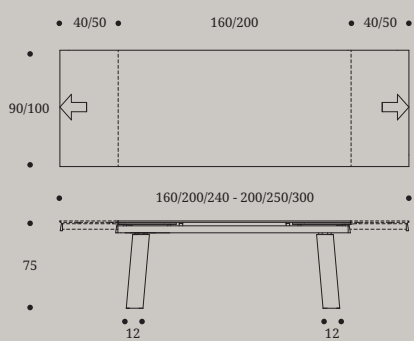

Mango table
page 68

—

*TABLES RELEVABLES
/ TRANSFORMING
COFFEE TABLES*

COM
PAR^I

ITALIAN DESIGN

TAVOLINI TRASFORMABILI

| Paris

transforming
coffee table

Praticità e bellezza sono irrinunciabili per chi cerca soluzioni brillanti, come il tavolo multiutility Paris. Riempie lo spazio con grazia trasformandosi con agilità da tavolino a tavolo, senza perdere il suo fascino.

design_Studio SV

La praticité et la beauté sont des éléments essentiels pour ce qui recherche des solutions intelligentes, comme la table relevable Paris. De table basse à table de repas, avec un simple geste, pour meubler la pièce avec classe.

Practicality and beauty are undeniable for those who seek brilliant solutions like multiutility table Paris. It fills the space with grace transforming with agility from coffee to dining table without losing charm.

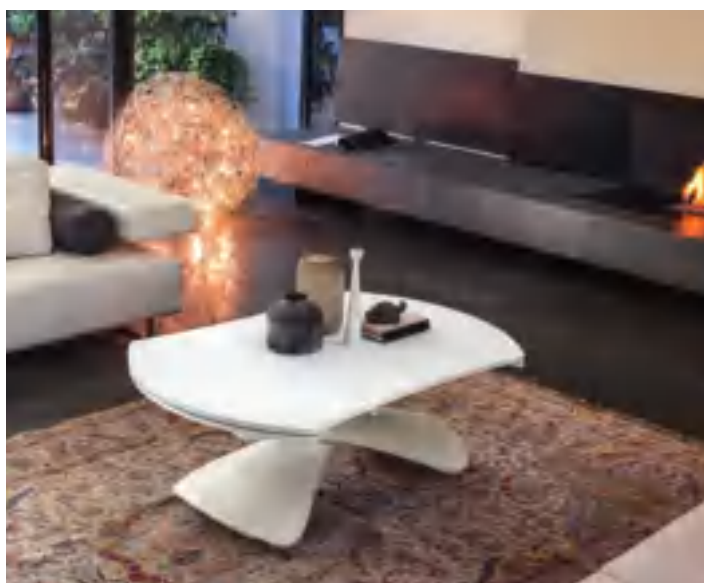

Base / Piétement / Base: verniciato, verni, coated - Bianco goffrato M24
Piano / Plateau / Top: vetro, verre, glass - Bianco acidato G04

TABLES RELEVABLES / TRANSFORMING COFFEE TABLES
TAVOLINI TRASFORMABILI



Sedia YOSHI WOOD

Gambe / Pieds / Legs: legno massiccio, bois massif, solid wood - Frassino canaletto W60

Seduta / Assise / Seat: tessuto, tissu, fabric Karina - Tortora TK02

| Paris_transforming coffee table





| Play

transforming
coffee table

**Un tavolo, mille occasioni.
Il trasformabile Play può
allungarsi, per aumentare
i posti a tavola, oppure
adattarsi in altezza ad altre
funzioni, come diventare
tavolino da salotto.**

design_Arter&Citton

Une table, mille occasions.
La table relevable Play peut
s'étendre, pour rajouter de
la place à table, ou ajuster
son hauteur pour plusieurs
fonctions, de table basse à table
de repas.

One table, thousands
occasions. The transforming
table Play can extend to host
more people or adapt in
height to other functions like
becoming a coffee table.



Base / Piétement / Base: verniciato, verni, coated - Nero goffrato M20
Piano / Plateau / Top: ceramica, céramique, ceramic - Oxide Bianco K10

TAVOLINI TRASFORMABILI



| Play_transforming coffee table

Il piano allungabile sulla base trasformabile fa di Play un passe-partout d'arredo indispensabile per uno stile di vita dinamico e al passo con le esigenze d'arredo attuali.

Le plateau extensible sur le piètement relevable de la table Play est le passe-partout pour un style de vie dynamique et en phase avec les besoins actuels.

The extending top on the transforming base makes Play a passe-partout piece of furniture, essential for a dynamic and in step with the actual furniture style.





Base / Piétement / Base: verniciato, verni, coated - Nero goffrato M20
Piano / Plateau / Top: ceramica, céramique, ceramic - Pietra di Savoia Antracite K11



| Simple Round

transforming
coffee table

| design_Com.p.ar

**Le forme elementari
custodiscono le soluzioni più
inaspettate: giochi geometrici
permettono di trasformare
con un semplice movimento
il tavolo Simple Round e dal
pranzo al salotto il passo è
molto breve.**

Les formes élémentaires
gardent les solutions les plus
inattendues : sa géométrie
permet de transformer la
table Simple Round, de table
basse à table de repas, avec un
simple geste.

The elementary shapes
guard the most unexpected
solutions: geometric games
allow table Simple Round
to transform with a simple
movement from a dining to a
coffee table.

Base / Piétement / Base: Cromo lucido M05

Piano / Plateau / Top: vetro, verre, glass - Cenere acidato G10



| **Simple Round**_transforming coffee table



*Base / Piétement / Base: Cromo lucido M05
Piano / Plateau / Top: vetro, verre, glass - Cenere acidato G10*



| DIMENSIONI
DIMENSIONES
DIMENSIONS

| Tavolini trasformabili

tables relevables, transforming coffee tables

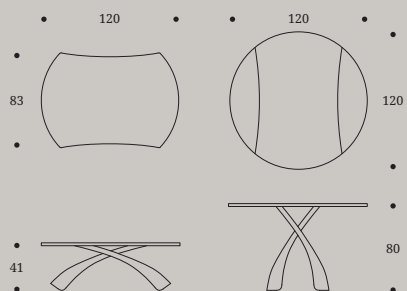

***Paris** transforming coffee table*
page 78

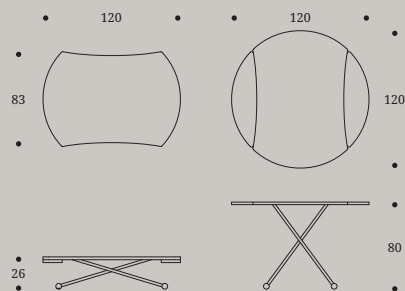

***Simple Round** transforming coffee table*
page 86

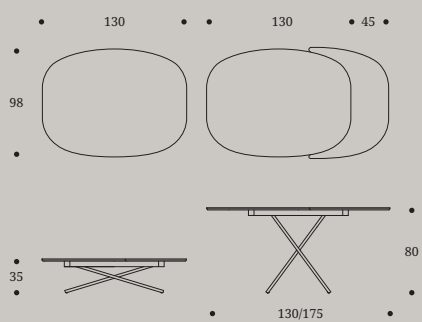

***Play** transforming coffee table*
page 82

—

CHAISES
FAUTEUILS
TAUBOURETS
/ CHAIRS
ARMCHAIRS
TOOLS

COM
PAR^I

ITALIAN DESIGN

SEDIE
POLTRONCINE
SGABELLI

| **Yoshi
Wood**
chair

Yoshi Wood è una sedia girevole caratterizzata da una base in cui le quattro gambe convergono al centro per dare spazio ad un'ampia e comoda seduta. I suoi volumi ricordano un abbraccio avvolgente, nello schienale che si prolunga ai lati.

design_Toshiyuki Yoshino

Yoshi Wood est une chaise pivotante avec un piètement où les quatre pieds se rejoignent pour soutenir l'assise. Ce produit rappelle un câlin confortable, avec son dossier qui s'étend sur les deux côtés.

Yoshi Wood is a swivel chair characterized by a base in which the four legs converge in the center to give space to a wide and comfy seat. The volume remind a comfortable hug in the back that prolongs to the sides.



Gambe / Pieds / Legs: legno massiccio, bois massif, solid wood - Frassino fumé W57
Seduta / Assise / Seat: ecopelle, eco-cuir, eco-leather - Bordeaux EB40

CHAISES / CHAIRS
SEDIE



*Gambe / Pieds / Legs: legno massiccio, bois massif, solid wood - Frassino canaletto W60
Seduta / Assise / Seat: tessuto, tissu, fabric Karina - Tortora TK02*

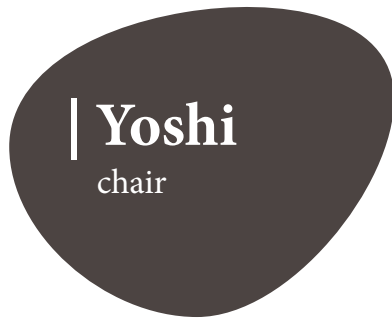

| **Yoshi**
chair

| design_Toshiyuki Yoshino

Costituita da un unico basamento a calice, Yoshi propone una base fissa e di design disponibile in metallo verniciato. Le impunture a vista nel rivestimento di seduta e schienale sottolineano le forme originali e la lavorazione di pregio nelle finiture.

Yoshi a un piètement fixe en métal verni, constitué par un seul pied et une structure tulipe. Les coutures du revêtement soulignent la qualité de la fabrication et des détails.

Composed of a unic goblet base, Yoshi proposes a fixed base available in coated metal. The broguing on the coating of the seat and back underline the original shape and the quality of the manufacturing of the finish.

Base / Piètement / Base: verniciato, verni, coated - Bronzo goffrato M19
Seduta / Assise / Seat: ecopelle, eco-cuir, eco-leather - Bordeaux EB40



| Minnie

design_Dario Delpin

La famiglia Minnie, nelle sue tre varianti sedia, poltroncina e sgabello si contraddistingue per la silhouette dalle linee morbide e sinuose.

La molteplicità di colorazioni disponibile la rende un complemento d'arredo di estrema versatilità, ideale per arredare soggiorni o camere da letto.

La famille Minnie, dans les trois versions chaise, fauteuil et tabouret se caractérise pour la silhouette aux lignes souples et sinueuses. La gamme des couleurs disponibles la rend un complément versatile et parfait pour meubler le séjour et la chambre.

Minnie family, in its three models chair, armchair and stool identifies itself for the silhouette from the soft and sinuous lines. The variety of available colours makes it an extremely adaptable piece of furniture, ideal to furnish living rooms or bedrooms.



Base / Piétement / Base: Cromo lucido M05
Seduta / Assise / Seat: tessuto, tissu, fabric Karina - Tortora TK02



Gambe / Piéds / Legs: verniciato, verni, coated - Lava opaco M28
Seduta / Assise / Seat: tessuto, tissu, fabric Karina - Grigio polvere TK03

Gambe / Piéds / Legs: verniciato, verni, coated - Lava opaco M28
Seduta / Assise / Seat: tessuto, tissu, fabric Karina - Verde acido TK09

| Minnie

chair

Minnie è la sedia dallo spirito giovane e dal carattere vivace. L'alto schienale dalle linee fluide ed avvolgenti invita all'accoglienza. Il suo profilo si precisa nel sottile bordo in tinta o a contrasto, rafforzandone lo stile. Le gambe in metallo la rendono ideale per arredare aree living o cucine particolarmente evolute.

design_Dario Delpin

Minnie est une chaise à l'esprit jeune et au caractère animé. Son dossier haut aux lignes fluides et enveloppantes vous invite à la bienvenue. Son profil se démarque dans la fine bordure ton-sur-ton ou contrastante renforçant son style. Les pieds en métal la rendent idéale pour la décoration d'espaces living ou de cuisines particulièrement sophistiquées.

Chair with a young spirit and a lively character. Its high back with its fluid and enveloping lines invites to hospitality. Its unique outline expressed on the contrasting or matching tiny piping enhances its style. Metal legs make it perfect to furnish advanced living areas or kitchens.



Gambe / Pieds / Legs: verniciato, verni, coated - Lava opaco M28
Seduta / Assise / Seat: pelle, cuir, leather - Grigio perla JP35
Profilo / Profile / Piping: ecopelle, eco-cuir, eco-leather - Fango EB15

CHAISES / CHAIRS
SEDIE



| Minnie_chair





| Minnie Soft armchair

design_Dario Delpin

Poltroncina dalla seduta ampia e dallo schienale accogliente, le sue linee morbide la rendono particolarmente confortevole. Le gambe dalla forma conica ben si predispongono ad accostarsi a tavoli da pranzo o a collocarsi in ingressi e zona notte con estrema versatilità e stile distintivo.

Fauteuil avec une ample assise et un dossier enveloppant, ses lignes la rend particulièrement confortable. Ses pieds en forme conique lui permettent de s'adapter aux tables de repas, ou de se situer dans les halls d'entrée ainsi que dans la zone nuit avec une versatilité absolue et un style distinctif.

Armchair with a wide seat and welcoming backrest, its soft lines make it particularly comfortable. Conical legs make Minnie armchair a versatile product, it can be used as an armchair for dining tables, entrances and bedrooms.



Gambe / Pieds / Legs: verniciato, verni, coated - Lava opaco M28
Seduta / Assise / Seat: pelle, cuir, leather - Antracite JP46

FAUTEUILS / ARMCHAIRS
POLTRONCINE



Minnie Swivel Soft

armchair

design_Dario Delpin

Minnie Swivel Soft si caratterizza per la presenza di una comoda base girevole in metallo verniciato. Il design accattivante definito dalla morbidezza della seduta e dello schienale in pelle la rende un oggetto d'arredo eclettico, utilizzabile come poltroncina per tavoli da pranzo, ingressi e camere da letto.

Minnie Swivel Soft est caractérisée par un confortable piètement pivotant en métal verni. Le design attrayant défini par la douceur de l'assise et du dossier en fait un complément éclectique, utilisable soit comme fauteuil pour les tables de repas, que dans les halls d'entrée et les chambres à coucher.

Minnie Swivel Soft armchair is characterized by its swivel coated base. The attractive design defined by the softness of the seat and of the back makes it an eclectic piece of furniture. It can be used as armchair for dining tables, entrances and bedrooms.



Base / Piètement / Base: verniciato, verni, coated - Tortora opaco M12

Seduta / Assise / Seat: pelle, cuir, leather - Camoscio JP36

Profilo / Profile / Piping: ecopelle, eco-cuir, eco-leather - Grigio pietra EB10

FAUTEUILS / ARMCHAIRS
POLTRONCINE



| **Minnie Swivel Soft_armchair**





| **Minnie
Fix**
stool

design_Dario Delpin

Sgabello fisso dalla seduta confortevole e generosa, caratterizzato dal profilo in tinta o a contrasto che ne delinea lo schienale. Le gambe coniche in metallo verniciato sostengono una seduta comoda e avvolgente.

Tabouret fixe à l'assise confortable et généreuse et au dossier enveloppant, caractérisé par le profil ton-sur-ton ou contrasté du dossier. Les pieds coniques en métal verni soutiennent une assise confortable.

Fixed stool with a comfortable and generous seat and enveloping backrest, characterized by contrasting or matching piping. Conical legs in coated metal support a comfy and immersive seat.



Gambe / Pieds / Legs: verniciato, verni, coated - Lava opaco M28
Seduta / Assise / Seat: tessuto, tissu, fabric Karina - Bianco TK01

TAUBOURETS / STOOLS
SGABELLI





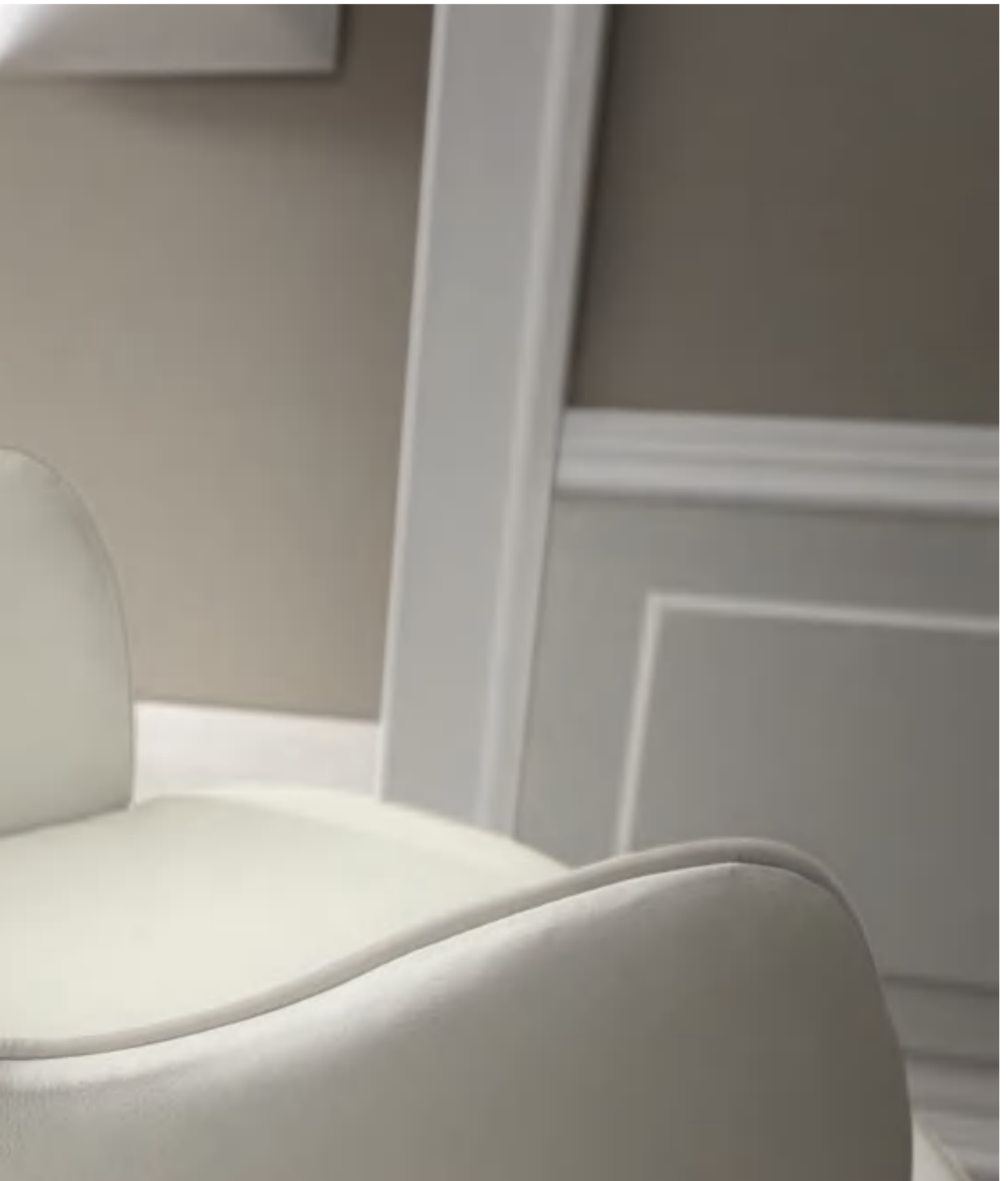

| Jolly

chair

design_Dario Delpin

La sedia Jolly è caratterizzata da un design dalle linee sinuose, esaltate da un profilo a contrasto che ne delinea lo schienale. La struttura in legno di frassino rivestita o tinta legno unita alla varietà di combinazioni e materiali di prestigio, consente di arredare ambienti classici e contemporanei.

Jolly, caractérisée par un design aux lignes sinueuses et raffinées, est tapissée en tissu avec une profile contrastée. La structure en frêne recouvert ou teintée bois, ainsi que la variété et les combinaisons de matériaux de prestige, permettent de créer des ambiances classiques et contemporaines.

Very refined and sinuous chair covered in fabric with contrast piping. The ash wood structure, in the same colour of the seat or in wood colour, and the varied prestige material combinations make Jolly chair suitable for classic or modern environment.



Gambe e seduta / Pieds et assise / Legs and seat:
tessuto, tissu, fabric Karina - Grigio platino TK24
Profilo / Profile / Piping: ecopelle, eco-cuir, eco-leather - Testa di moro EB57

CHAISES / CHAIRS
SEDIE



Gambe / Pieds / Legs: legno massiccio, bois massif, solid wood - Frassino canaletto W60
Seduta / Assise / Seat: tessuto, tissu, fabric Karina - Grigio polvere TK03
Profilo / Profile / Piping: ecopelle, eco-cuir, eco-leather - Testa di moro EB57

| Jolly_chair



***Gambe e seduta** / Pieds et assise / Legs and seat: tessuto, tissu, fabric Karina - Grigio platino TK24
Profilo / Profile / Piping: ecopelle, eco-cuir, eco-leather - Testa di moro EB57*



| Jolly
Soft
chair

Jolly Soft, con una seduta raffinata ed un'importante struttura in legno, grazie alla varietà di combinazioni si integra perfettamente sia in un ambiente moderno sia in un contesto classico. La seduta e lo schienale sono rivestiti in morbida pelle, le gambe di forma conica sono realizzate in frassino o su richiesta rivestite.

design_Dario Delpin

Jolly Soft est une chaise très raffinée avec une structure en bois qui, grâce à la variété des combinaisons, peut être déclinée soit à un design moderne que classique. L'assise et le dossier sont recouverts en cuir souple, les pieds coniques sont en frêne ou revêtus sur demande.

Very elegant chair, its ash wood structure with a wide range of material choice combination makes Jolly Soft chair suitable with a classic and a modern design. Seat and back are coated with a soft piece of leather; conical legs in the picture are realized in walnut canaletto solid wood but can be leather covered upon request.



Gambe / Pieds / Legs: legno massiccio, bois massif, solid wood - Frassino canaletto W60
Seduta / Assise / Seat: pelle, cuir, leather - Cipria JP34
Profilo / Profile / Piping: ecopelle, eco-cuir, eco-leather - Testa di moro EB57

CHAISES / CHAIRS
SEDIE



| Jolly Soft_chair





| Jolly

armchair

design_Dario Delpin

La poltroncina Jolly offre un'ampia seduta confortevole caratterizzata da volumi contenuti.

L'ampia scelta dei materiali di rivestimento di schienale e seduta si estende anche alle gambe, per un total look impeccabile.

Le fauteuil Jolly offre une assise large et confortable, caractérisée par un petit volume. L'ample gamme des revêtements pour le dossier, l'assise et les pieds donne à ce produit un total look impeccable.

The small armchair Jolly offers a wide and comfortable seat characterized by contained volume. The wide choice of material for the coating of seat and back extends also to the legs for an impeccable total look.



FAUTEUILS / ARMCHAIRS
POLTRONCINE



Gambe e seduta / Pieds et assise / Legs and seat:
tessuto, tissu, fabric Karina - Verde acido TK09, Blu elettrico TK19,
Amaranto TK13
Profilo / Profile / Piping: ecopelle, eco-cuir, eco-leather - Testa di moro EB57

Gambe / Pieds / Legs:
legno massiccio, bois massif, solid wood - Frassino canaletto W60
Seduta / Assise / Seat:
tessuto, tissu, fabric Karina - Grigio lava TK04, Tortora TK02
Profilo / Profile / Piping: ecopelle, eco-cuir, eco-leather - Testa di moro EB57

| Jolly
Soft
armchair

La poltroncina Jolly Soft si presenta con un'ampia seduta dallo schienale morbido ed avvolgente. Le gambe, in frassino tinto canaletto o rivestite, evocano lo stile anni 50 che rivive una nuova stagione nell'arredo contemporaneo. Una poltroncina che si integra perfettamente con diversi stili d'arredo, dal classico al moderno, con sobria eleganza formale.

design_Dario Delpin

Le fauteuil Jolly Soft se présente avec une large assise et un dossier enveloppant et confortable, recouvert en cuir soft. Les pieds, en frêne teinté canaletto ou revêtus, évoquent le style années 50 qui fait revivre une nouvelle saison dans le mobilier contemporain. Un fauteuil qui bien s'intègre à différents styles de mobilier, du classique au moderne, avec une élégance formelle.

Armchair with a wide seat and enveloping backrest covered with soft leather. Ash wood legs painted canaletto or coated, evoke the 50's style that relives a new season on the contemporary furnishing. A formal elegant armchair that is comfortable with different furnishing solutions, from modern to classic.



Gambe / Pieds / Legs: legno massiccio, bois massif, solid wood - Frassino canaletto W60
Seduta / Assise / Seat: pelle, cuir, leather - Testa di moro JP44

FAUTEUILS / ARMCHAIRS
POLTRONCINE



| Jolly Soft_armchair





| Jolly Cross Soft

armchair

Grazie agli elementi incrociati della base, la poltroncina Jolly Cross Soft assume un'aria più innovativa ed accattivante. Un cambio di stile che la rende unica nel suo genere, senza comprometterne il comfort della seduta.

design **Dario Delpin**

Grâce à son piètement croisé, le fauteuil Jolly Cross Soft a un design plus léger et attrayant. Un changement de style qui rend ce produit unique et reconnaissable, sans compromettre le confort de l'assise.

Thanks to the crossed elements of its base, Jolly Cross Soft armchair assumes an innovative and charming look. A change of style which makes unique this model, without compromising the comfort of the seat.



Base / Piètement / Base: verniciato, verni, coated - Bronzo goffrato M19
Seduta / Assise / Seat: pelle, cuir, leather - Testa di moro JP44

FAUTEUILS / ARMCHAIRS
POLTRONCINE





design_Dario Delpin

La serie Jolly si amplia e presenta la versione sgabello. Grazie alle forme confortevoli ed all'ampia scelta di rivestimenti disponibili, Jolly stool garantisce comodità e grande adattabilità ai diversi stili d'arredo, dai più sobri ai più ricercati.

La série Jolly est enrichie par ce tabouret: confortable, ce produit assure une grande commodité et adaptabilité aux tous les styles, les plus simples et les plus recherchés, grâce à la large choix des revêtements disponibles.

The Jolly serie expands and presents the stool version: with comfortable shapes, it guarantees comfort and huge adaptability to many different furnishing styles, from the most sober to the most polished, thanks to the wide range of materials available for coating.

Gambe / Pieds / Legs: legno massiccio, bois massif, solid wood - Frassino canaletto W60
Seduta / Assise / Seat: tessuto, tissu, fabric Karina - Verde acido TK09
Profilo / Profile / Piping: ecopelle, eco-cuir, eco-leather - Testa di moro EB57

TAUBOURETS / STOOLS
SGABELLI

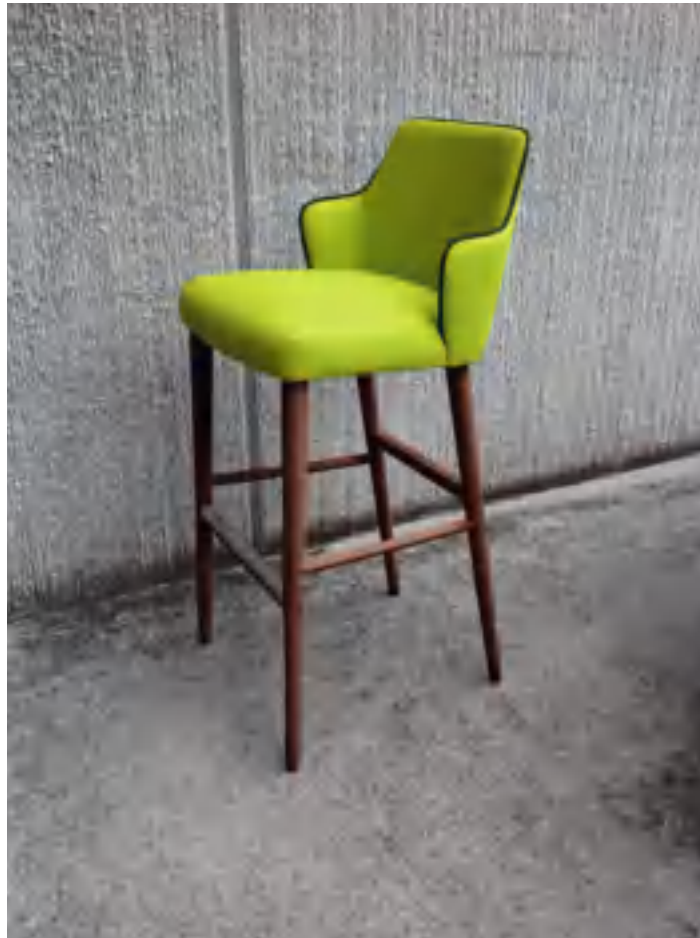

Maya Wood

chair

design_Dario Delpin

Maya Wood, elemento di classe e raffinatezza, propone una seduta in soffice velluto con schienale dall'effetto trapuntato, disponibile in più colorazioni. L'eleganza delle gambe in frassino tinto si accompagna piacevolmente al profilo abbinato o a contrasto della seduta, creando un gradevole gioco di stile.

Maya Wood, élément de classe et élégance, a une assise en velours avec un dossier matelassé, disponible en différentes couleurs. L'élégance des pieds en frêne teinté est assortie au bord ton sur ton ou contrasté de l'assise, pour un jeu de style.

Maya Wood, classy and sophisticated element, proposes a soft velvet seat with backrest from the quilted effect, available in many colours. The elegance of the painted legs matches pleasantly with the profile in the same colour or in contrast, creating a lovely style game.

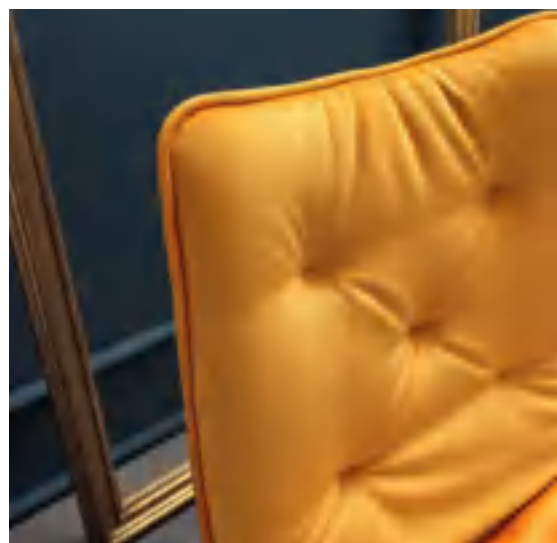

Gambe / Pieds / Legs: legno massiccio, bois massif, solid wood - Frassino canaletto W60
Seduta / Assise / Seat: velluto, velours, velvet - Mostaza VL31

CHAISES / CHAIRS
SEDIE



| Maya

chair

La sedia Maya nella versione con gambe in metallo, è caratterizzata da una forte e spigliata personalità. Il suo design minimal ben si integra in spazi living sia classici che moderni. Le gambe, lievemente inclinate e leggere creano un piacevole contrasto con la morbidezza delle linee della sinuosa seduta.

design_Dario Delpin

La chaise Maya dans sa version avec les pieds en métal, est caractérisée par une forte personnalité. Son design minimal s'intègre bien aux espaces quotidiens. Les pieds fins et carrés en métal créent un doux contraste avec la souplesse des lignes de son assise sinueuse.

Maya chair with metal legs, is characterized by a strong personality. Its minimalist design is perfect for living areas, classic or modern. The metal rod legs create a nice contrast with the sweetness of the lines of the curvy seat.



Gambe / Pieds / Legs: verniciato, verni, coated - Grafite goffrato M11
Seduta / Assise / Seat: velluto, velours, velvet - Khaki VL87

CHAISES / CHAIRS
SEDIE



| Polly

Grintosa ma allo stesso tempo elegante, la linea Polly si adatta bene ad arricchire non solo l'atmosfera di casa ma anche ad ammobiliare uffici ed aree di lavoro. L'inconfondibile dettaglio dello schienale trapuntato esalta l'idea di comfort della seduta e garantisce un tocco di classe all'ambiente circostante.

design_Dario Delpin

Attrayante et élégante, la collection Polly s'adapte parfaitement à l'atmosphère de la maison ou à l'ambiance d'un bureau ou d'un espace de travail. Le détail du dossier matelassé souligne le confort de l'assise et assure une touche de classe à l'environnement.

Gutsy but at the same time elegant, Polly line is well suited to enrich not only home atmosphere but also to furnish offices and work areas. The unmistakable detail of its quilted back glorifies the idea of comfort of the seat and guarantees a classy touch to the surrounding space.



Gambe e seduta / Pieds et assise / Legs and seat:
tessuto, tissu, fabric Karina - Blu elettrico TK19



Gambe e seduta / Pieds et assise / Legs and seat:
tessuto, tissu, fabric Karina - Grigio fumo TK22



Gambe e seduta / Pieds et assise / Legs and seat:
tessuto, tissu, fabric Karina - Testa di moro TK06



Gambe e seduta / Pieds et assise / Legs and seat:
tessuto, tissu, fabric Karina - Grigio polvere TK03



| Polly_chair



***Gambe e seduta** / Pieds et assise / Legs and seat:
tessuto, tissu, fabric Karina - Grigio fumo TK22, Grigio polvere TK03*



| Polly Wood

chair

Uno stile formale si fa interprete di ambienti caldi ed accoglienti valorizzando ogni spazio abitativo. Polly Wood esibisce uno schienale trapuntato sul lato esterno per lasciare minimal l'interno, qui evidenziato da un raffinato tessuto bianco. Le gambe, in essenza di frassino tinto canaletto, lievemente squadrate comunicano solidità e robustezza.

design_Dario Delpin

Un style formel interprète d'ambiances chaleureux et accueillants, mettant en valeur chaque espace de vie. Polly Wood présente un dossier matelassé et un intérieur minimal, qui met en évidence un tissu blanc raffiné. Les pieds légèrement en forme carrée transmettent solidité et robustesse, présentés en essence Frêne teinté canaletto.

A formal style interprets warm and welcoming spaces giving value to every room. Polly Wood exhibits a quilted back on the external face and leaves a minimal style for internal face, with a refined white fabric. The slightly squared legs communicate solidity, here represented in ash painted canaletto.



Gambe / Pieds / Legs: legno massiccio, bois massif, solid wood - Frassino canaletto W60
Seduta / Assise / Seat: tessuto, tissu, fabric Karina - Testa di moro TK06
Schienale / Dossier / Backrest: tessuto, tissu, fabric Karina - Bianco TK01

CHAISES / CHAIRS
SEDIE







| Polly Wood_chair



Gambe / Pieds / Legs: *legno massiccio, bois massif, solid wood - Frassino canaletto W60*

Seduta e schienale / Assise et dossier / Seat and backrest: *ecopelle, eco-cuir, eco-leather - Zenzero EB59*



| **Polly
Wood**
armchair

La poltroncina Polly Wood invita al relax con la sua seduta ergonomica, dallo schienale lavorato a trapunta rappresentata in ecopelle nabuk. La struttura, realizzata in frassino tinto canaletto, completa in armonia questo articolo d'arredo esclusivo.

design_Dario Delpin

Le fauteuil Polly Wood vous invite dans son assise ergonomique accompagnée d'un dossier matelassé en eco-cuir nabuk. La structure, réalisée en frêne teinté Noyer Canaletto, complète en harmonie ce complètement exclusif.

Polly Wood armchair invites you on its ergonomic seat accompanied by an adherent and padded back in eco-leather nabuk. The ash wood structure is completed by painted canaletto legs. Its lightly squared shape that thins out on the bottom has been developed to emphasize its formal elegance.



Gambe / Pieds / Legs: legno massiccio, bois massif, solid wood - Frassino canaletto W60
Seduta / Assise / Seat: ecopelle, eco-cuir, eco-leather Nabuk - Antracite NB07

FAUTEUILS / ARMCHAIRS
POLTRONCINE



| Polly Wood_armchair





FAUTEUILS / ARMCHAIRS
POLTRONCINE

| Polly Wood

stool

Polly Wood è lo sgabello trendy che conserva le raffinate proporzioni della poltroncina alzando il livello della seduta ad un'altezza di 65 cm da terra. Soluzione d'arredo ideale per servire isole di cucine contemporanee o banconi di raffinati locali di tendenza.

design **Dario Delpin**

Le tabouret Polly Wood préserve les proportions raffinées du petit fauteuil en élevant le niveau du siège à une hauteur de 65 cm du sol. Solution d'ameublement idéale pour servir les îlots de cuisines contemporaines ou devant les comptoirs de lieux branchés et raffinés.

Polly Wood stool preserves the refined proportions of the armchair raising the seat level up to 65 cm. Ideal furnishing solution for contemporary kitchen islands or counters for trendy establishment.



Gambe / Pieds / Legs: legno massiccio, bois massif, solid wood - Frassino canaletto W60
Seduta / Assise / Seat: tessuto, tissu, fabric Karina - Bianco TK01

TAUBOURETS / STOOLS
SGABELLI



| Polly Wood_stool





Fenice

armchair

design_Dario Delpin

Fenice è una poltrona dal design sinuoso che accenna nella forma interna dello schienale una raffinata arcciatura che ne esalta il disegno. Il contrasto creato dal bicolore tra interno ed esterno dello schienale e le gambe coniche disponibili in frassino tinto, rendono la poltroncina un elemento d'arredo prestigioso e al contempo dinamico.

Fenice est le fauteuil au design sinueux, avec un dossier légèrement enroulé. Le contraste entre les deux couleurs du dossier et les pieds en frêne teinté rend ce produit un complètement vraiment intéressant et dynamique.

Fenice is an armchair from the sinuous design. In the inner part of the backrest, hints a refined curling which intensifies the drawing. The contrast created by the bicolour between backrest inside and outside, and the conical legs in painted ash, make this armchair a prestigious and dynamic piece of furniture.



Gambe / Pieds / Legs: legno massiccio, bois massif, solid wood - Frassino canaletto W60
Seduta / assise / seat: velluto, velours, velvet - Lion VL05
Retro / arrière / back: velluto, velours, velvet - Taupe VL14

FAUTEUILS / ARMCHAIRS
POLTRONCINE



| **Fenice_armchair**





FAUTEUILS / ARMCHAIRS
POLTRONCINE

Fenice

stool

Lo sgabello Fenice eleva il suo spirito eclettico portando la comoda seduta dell'omonima poltrona ad un'altra altezza, per offrire servizio accostato a banconi o ad isole presenti nell'arredo moderno. La struttura è qui presentata in frassino tinto canaletto. Lo schienale si veste per l'occasione di un morbido velluto bicolore che segue nella seduta con il tono più chiaro.



design_Dario Delpin

Le tabouret Fenice rehausse son esprit éclectique en apportant le confortable siège de l'homonyme fauteuil à une autre hauteur, pour offrir un service déclinable aux des comptoirs ou aux îles dans un mobilier contemporain. La structure, en frêne teinté canaletto, de l'assise et du dossier est recouverte d'un doux velours bicolore.

Fenice stool raises its eclectic spirit bringing the comfortable seat of the homonymous armchair to another height providing different solutions for modern counters or kitchen islands. Ash-wood structure is coated in soft, bicoloured, velvet fabric.

Gambe / Pieds / Legs: legno massiccio, bois massif, solid wood - Frassino canaletto W60
Seduta / assise / seat: velluto, velours, velvet - Lion VL05
Retro / arrière / back: velluto, velours, velvet - Taupe VL14

TAUBOURETS / STOOLS
SGABELLI



| Fenice_stool





| Clery

chair

design_**Com.p.ar**

Monocolore o con seduta a contrasto, la sedia Clery si presenta in tutta la sua semplicità ed efficienza. L'alto schienale si curva a seguire le forme naturali della schiena per garantire una seduta confortevole.

Une seule couleur ou avec l'assise en contraste, la chaise Clery se montre dans toute sa simplicité et son efficacité. Le dossier haut se plie en suivant les formes naturelles du dossier, pour assurer toujours un grand confort.

Unicolour or with contrasted seat, the Clery chair presents in all its simplicity and efficiency. The high back bends to follow the natural shape of your back to guarantee a comfortable seat.

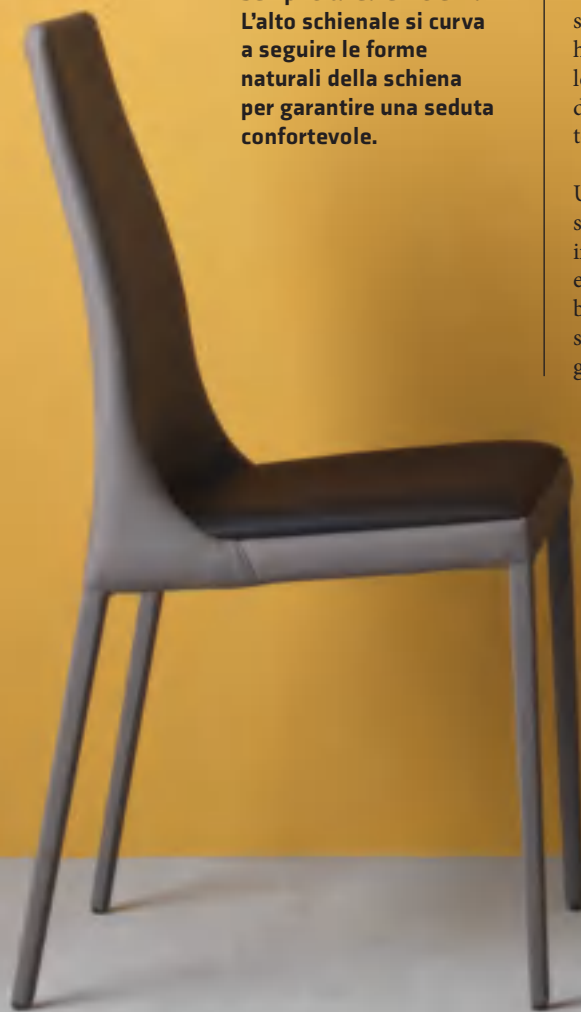

*Gambe e schienale / Pieds et dossier / Legs and backrest: ecopelle, eco-cuir, eco-leather - Argilla EB14
Seduta / Assise / Seat: ecopelle, eco-cuir, eco-leather - Testa di moro EB57*

CHAISES / CHAIRS
SEDIE



Gambe e schienale / Pieds et dossier / Legs and backrest: ecopelle, eco-cuir, eco-leather - Acciaio EB04
Seduta / Assise / Seat: ecopelle, eco-cuir, eco-leather - Cenere EB07, Acciaio EB04

Rosa

chair

design_Com.p.ar

La sedia Rosa, caratterizzata da linee geometriche ed al contempo snelle, si propone con seduta e schienale della stessa finitura, qui visibile in bianco. L'effetto d'insieme di sobria eleganza la rende versatile ed adattabile in ogni contesto.

La chaise Rosa, caractérisée par des lignes géométriques, est présentée avec une assise et un dossier dans la même finition, ici en blanc. L'effet final de sobriété et élégance la rend parfaite dans tous les contextes.

Rosa chair, characterized by geometrical and slim lines, is proposed with seat and backrest in the same finish, here white. The overall effect is of sober elegance, which makes the chair adaptable to any context.



Gambe e seduta / Pieds et assise / Legs and seat: pelle, cuir, leather - Bianco JP30



CHAISES / CHAIRS
SEDIE

Mila

chair & armchair

design_Dario Delpin

La sedia Mila è un articolo unico nel suo genere: si presenta con un lato imbottito che accoglie la seduta e completa il suo stile con il retro rigido coordinato alla finitura delle gambe. Il modello Mila si arricchisce della versione poltroncina, caratterizzata dai braccioli dalle curve determinate e grintose.

La chaise Mila a une partie rembourrée, où s'asseoir, et le dos rigide et coordonné à la finition des pieds.

La collection Mila est enrichie par la version fauteuil, caractérisé par des accoudoirs aux lignes souples et sinueuses.

Mila chair is an article unique in its kind: it presents itself with a stuffed side where you can accommodate and rigid back, coordinated to the finish of the legs. Mila family is enriched by the armchair version, with armrests from soft and sinuous curves.



Gambe / Pieds / Legs: legno massiccio, bois massif, solid wood - Noce canaletto

Seduta / Assise / Seat: ecopelle, eco-cuir, eco-leather - Bianco EB01

Retro / Arrière / Back: legno impiallacciato, bois placage, veneered wood - Noce canaletto W10



Gambe / Pieds / Legs: legno massiccio, bois massif, solid wood - Noce canaletto
Seduta / Assise / Seat: ecopelle, eco-cuir, eco-leather - Bianco EB01
Retro / Arrière / Back: legno impiallacciato, bois placage, veneered wood - Noce canaletto W10



design_Dario Delpin

Lo sgabello girevole Mila conserva il caratteristico retro rigido che esalta la funzionalità della seduta imbottita. Il sostegno in metallo verniciato o cromato, regolabile in altezza e dotato di un pratico poggipiedi, permette di utilizzare lo sgabello accanto a banconi ed isole.

Le tabouret pivotant Mila garde son distinctif dos, qui exalte la fonctionnalité de l'assise rembourrée. Le piètement en métal verni ou chromé, réglable en hauteur et avec repose-pied, permet d'utiliser ce tabouret à cote d'un comptoir ou dans une cuisine avec l'île.

Mila Swivel stool conserves the distinctive rigid back which exalts the functionality of the padded seat. The coated or chromed metal adjustable support, equipped with a practical footrest, allows to use the stool next to counter and kitchen island.

Base / Piètement / Base: Cromo lucido M05

Seduta / Assise / Seat: ecopelle, eco-cuir, eco-leather - Acciaio EB04, Rosso EB35

Retro / Arrière / Back: legno impiallacciato, bois placage, veneered wood - Rovere grigio W02





Monika

chair

design_Andrea Lucatello

Nella sedia Monika le forme asciutte e compatte di seduta e schienale si presentano in molteplici tonalità di ecopelle e pelle, per assecondare i toni caldi o freddi delle gambe in legno.

Concernant la chaise Monika, les lignes simples de l'assise et du dossier ont plusieurs teintes d'éco-cuir et cuir, pour s'adapter aux tons chaleureux ou froids des pieds en bois.

In the Monika chair the dry shapes of seat and back are presented in various tones of eco-leather and leather, to indulge the warm or cold tones of the wooden legs.

Gambe / Pieds / Legs: legno massiccio, bois massif, solid wood - Frassino canaletto W60

Seduta / Assise / Seat: ecopelle, eco-cuir, eco-leather - Nocciola EB30

Retro / Arrière / Back: ecopelle, eco-cuir, eco-leather - Testa di moro EB57

Gambe / Pieds / Legs: legno massiccio, bois massif, solid wood - Frassino grigio W52

Seduta / Assise / Seat: ecopelle, eco-cuir, eco-leather - Acciaio EB04

CHAISES / CHAIRS
SEDIE





design_Studio SV

Le morbide ed accoglienti forme imbottite della sedia Luxi garantiscono ottime prestazioni ed una comoda seduta. Il suo stile informale la rende inoltre facilmente inseribile in diversi contesti.

Les lignes douces et confortables de la chaise Luxi assurent une assise performante et confortable. Son style informel la rend parfaite pour tous les ambiances.

The soft and welcoming filled up shapes of Luxi chair guarantee an excellent performance and a comfortable seat. Its informal style makes Luxi an easy piece of furniture that can be adapted to many different spaces.

Gambe / Pieds / Legs: legno massiccio, bois massif, solid wood - Frassino canaletto W60
Seduta / Assise / Seat: tessuto, tissu, fabric Karina - Tortora TK02

CHAISES / CHAIRS
SEDIE





design_Studio SV

La stessa comodità della sedia Luxi si ritrova nello sgabello, con un cambio di proporzioni per l'utilizzo con banconi o isole. La vasta possibilità di scelta tra i colori disponibili dei tessuti, rende questo prodotto estremamente versatile ed adattabile ad arredamenti dallo stile sobrio o insolito.

On peut retrouver le même confort de la chaise Luxi dans le tabouret correspondant, avec des proportions différentes pour l'utiliser à cote d'une table haute ou d'un îlot de cuisine. La large gamme des couleurs disponibles permet d'avoir un produit très adaptable à chaque déco, même la plus originale.

The same comfort of Luxi chair is replicated in the Luxi stool, with a change in proportions for using it with counter tops. The wide range of colours and textiles makes this product extremely versatile and adaptable to sober but also to unusual furniture styles.

Gambe / Pieds / Legs: legno massiccio, bois massif, solid wood - Frassino fumé W57
Seduta / Assise / Seat: tessuto, tissu, fabric Karina - Verde acido TK09

TAUBOURETS / STOOLS
SGABELLI

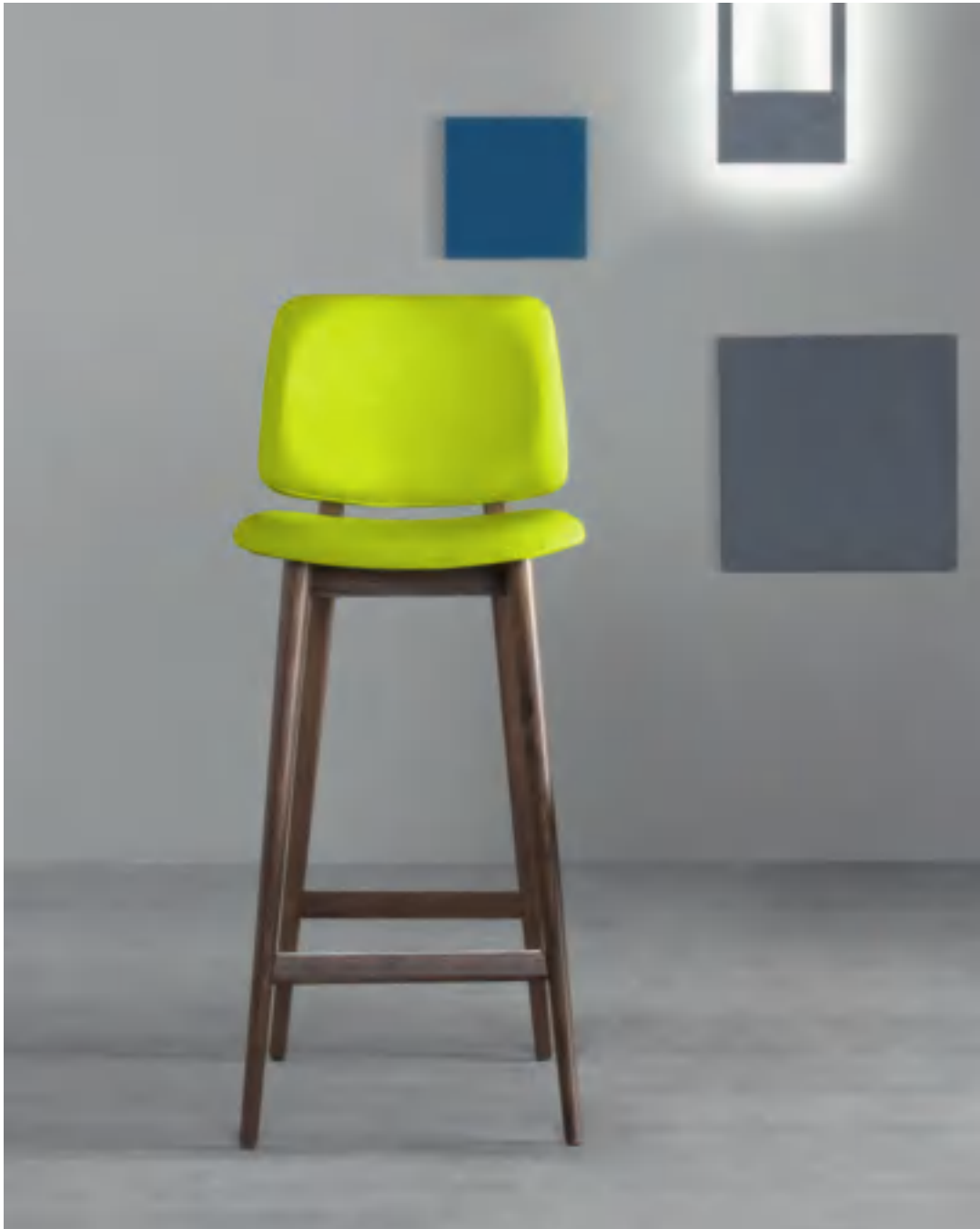

| Marilyn

chair

design_Com.p.ar

Il sinuoso schienale della sedia Marilyn sembra dare continuità alla leggerezza delle sottili gambe che la sostengono. La finitura in ecopelle o pelle nelle varie colorazioni riveste con eleganza ogni suo dettaglio.

Le sinueux dossier de la chaise Marilyn donne de la légèreté aux pieds de ce produit. La finition en eco-cuir ou cuir dans les différentes couleurs recouvre complètement cette chaise, dans tous ses détails.

The sinuous back of the Marilyn chair seems to give continuity to the lightness of the thin legs. The eco-leather or leather finish in its wide range of colours coats elegantly every detail of the chair.

Gambe e seduta / Pieds et assise / Legs and seat:
ecopelle, eco-cuir, eco-leather -
Giallo limone EB18, Rosso EB35, Viola EB48







| **Slim**
chair

| design_Com.p.ar

Il basamento cromato della sedia Slim riflette l'agilità di un ambiente dinamico. L'abbinamento alla finitura pelle o ecopelle nei toni neutri ne definisce ancor più lo stile impeccabile.

Le piètement chromé de la chaise Slim s'adapte aux pièces les plus dynamiques. La combinaison avec les couleurs en cuir ou eco-cuir donne à ce produit un style impeccable.

The chromed base of chair Slim reflects the agility of a dynamic space. The match with the leather or eco-leather finish in neutral tones defines even more a flawless style.

Base / Piètement / Base: Cromo lucido M05

Seduta / Assise / Seat: pelle, cuir, leather - Bianco JP30, Antracite JP46, Grigio lava JP45

CHAISES / CHAIRS
SEDIE



| Mary

chair

| design_Com.p.ar

La silhouette uniforme della sedia Mary è interrotta da una mezzaluna sullo schienale, che ne facilita la presa. Le linee pulite di ogni elemento sono tracciate dalla cucitura che definisce elegantemente tutte le bordure.

La silhouette uniforme de la chaise Mary est interrompue par une demi-lune dans le dossier, qui permet une manipulation plus facile. Les lignes simples de chaque élément sont valorisées par une couture élégante dans tous les détails.

The uniform silhouette of chair Mary is interrupted from a half-moon on the back that facilitates its grabbing. The clean lines of each elements are traced by the seam that elegantly defines all borders.

Gambe e seduta / Pieds et assise / Legs and seat:
ecocuio, eco-cuir épais, thick eco-leather - Bianco EK01, Testa di moro EK08

CHAISES / CHAIRS

SEDIE



| Flora

chair

design **Andrea Lucatello**

Perfetta unione tra semplicità e stile sobrio, la sedia Flora si contraddistingue per la sua ampia seduta comoda, sorretta da delle gambe importanti in legno a vista. La molteplicità dei colori disponibili rende questo prodotto adattabile ad ogni zona della casa senza rinunciare al comfort.

Parfaite liaison entre la simplicité et la sobriété, la chaise Flora se caractérise par son assise large et confortable, soutenue par des pieds importants en bois. La gamme des couleurs disponible rend ce produit parfait pour tous les pièces de la maisons, sans jamais renoncer au confort.

Perfect combination between simplicity and sober style, Flora chair stands out for its wide and comfy seat, supported by important legs in exposed wood. The variety of available colours makes this product suitable for every room of the house, without giving up the comfort.

Gambe / Pieds / Legs: legno massiccio, bois massif, solid wood - Frassino canaletto W60
Seduta / Assise / Seat: ecopelle, eco-cuir, eco-leather - Argilla EB14

CHAISES / CHAIRS
SEDIE



Liza

armchair

design_Andrea Lucatello

Poltrona dalla seduta ampia che comprende un cuscino poggiatesta morbido ed avvolgente per un comfort esclusivo.

La struttura in metallo svolge la doppia funzione di bracciolo leggermente imbottito e di gamba, proseguendo fino a terra.

Fauteuil avec une assise confortable et un coussin souple pour un confort exclusif. La structure en métal a la double fonction de bras rembourré et de pied, en arrivant jusqu'au sol.

Armchair from a wide seat which includes a lower back pillow, soft and enveloping for an exclusive comfort. The metal structure has a double function of armrest and leg, continuing to the floor.

Gambe / Pieds / Legs: Cromo lucido M05
Seduta / Assise / Seat: pelle, cuir, leather: Camoscio JP36, Rosso JP41

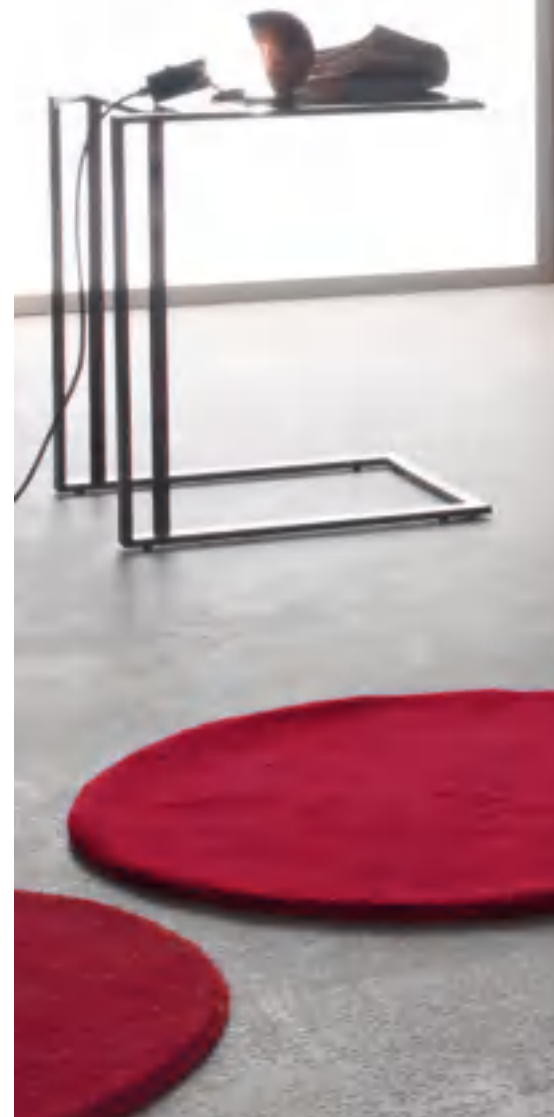



| **Rosy**
armchair

Rosy è la poltroncina dalla forma avvolgente e dai volumi soffici. Le gambe coniche che la sostengono ricordano la grazia di una ballerina sulle punte.

design_Com.p.ar

Rosy est le fauteuil aux formes enveloppantes et aux volumes souples. Les pieds coniques rappellent l'élégance d'une danseuse.

Rosy is a small armchair with an embracing shape and soft volumes. The conical legs sustain the armchair reminding to the grace of a tiptoe dancer.



Gambe / Pieds / Legs: verniciato, verni, coated - Nero gofrato M20
Seduta / Assise / Seat: ecopelle, eco-cuir, eco-leather Nabuk - Bianco NB08, Grigio chiaro NB09, Antracite NB07

FAUTEUILS / ARMCHAIRS
POLTRONCINE





design_Dario Delpin

Poltroncina in finitura ecopelle o velluto con cuscino tono su tono e gambe in tinta canaletto. Le forme vagamente sferiche e avvolgenti abbinate al calore del legno fanno di Desire un comodo rifugio per i momenti di relax.

Fauteuil en finition éco-cuir ou velours, avec un coussin ton sur ton et des pieds en canaletto. Les lignes arrondies et coordonnées à la chaleur du bois rendent la Desire un produit parfait pour votre relax.

Desire is a small armchair with eco-leather or velvet finish, ton sur ton pillow, and canaletto legs. The vaguely spherical shape matched to the heat of wood makes Desire a comfortable shelter for relaxed moments.

Gambe / Pieds / Legs: legno massiccio, bois massif, solid wood - Frassino canaletto W60

Seduta / Assise / Seat: ecopelle, eco-cuir, eco-leather - Acciaio EB04

Schienale / Dossier / Backrest: ecopelle, eco-cuir, eco-leather - Grigio perla EB10

Seduta e schienale / Assise et dossier / Seat and backrest: velluto, velours, velvet - Camel VL04



| Jane Fix

armchair

design_Arter&Citton

La particolare forma della poltroncina Jane crea un perfetto connubio tra comfort e design. L'avvolgente seduta si sposa con grazia alla base fissa in legno o alla più dinamica base girevole in metallo.

La forme spéciale du fauteuil Jane crée une liaison parfaite entre le confort et le design. L'assise confortable se décline parfaitement avec le piètement fixe en bois ou avec le piètement pivotant en métal.

The particular shape of Jane armchair creates a perfect combination between comfort and design. The wrap-around seat gracefully matches both with its fixed wooden base and with its more dynamic swivel metal base.



*Gambe / Pieds / Legs: legno massiccio, bois massif, solid wood - Frassino canaletto W60
Seduta / Assise / Seat: tessuto, tissu, fabric Karina - Amaranto TK13, Verde acido TK09, Bianco TK01*

FAUTEUILS / ARMCHAIRS
POLTRONCINE





Desy
armchair

design_Arter&Citton

La poltroncina Desy si presenta come un elemento monolitico dallo spiccato design moderno e ricercato. Le curve linee giocose e la vivacità dei colori proposti fanno di questo articolo un complemento d'arredo irrinunciabile per uno stile dinamico e contemporaneo.

Le fauteuil Desy se présente comme un élément monolithique, au design moderne et raffiné. Les lignes courbes et la vivacité des couleurs rendent ce produit un complément indispensable pour un style dynamique et actuel.

Desy armchair presents itself as a monolithic element from modern and sophisticated design. Its curvy and playful lines and the liveliness of proposed colours make this article an essential piece of furniture for a dynamic and contemporary style.

Struttura / Structure / Body:

ecopelle, eco-cuir, eco-leather - Rosso EB35, Nero EB08, Bianco EB01, Avorio EB03



| Desy_armchair





FAUTEUILS / ARMCHAIRS
POLTRONCINE



design_Com.p.ar

Uno sgabello versatile, sinonimo di praticità e dinamismo. Romy soddisfa tutte le esigenze d'arredo rivestendosi di colore per ogni occasione.

Un tabouret polyvalent, synonyme de praticité et dynamisme. Romy satisfait tous les besoins, grâce à ses revêtements et ses couleurs pour n'importe quelle occasion.

Romy is a versatile stool, synonym of practicality and dynamism. Romy satisfies every furniture need dressing up with colour for every occasion.

Gambe e seduta / Pieds et assise / Legs and seat: ecopelle, eco-cuir, eco-leather - Rosso EB35

TAUBOURETS / STOOLS
SGABELLI



| Yumi

stool

design_ Com.p.ar

Sgabello in metallo regolabile in altezza, con poggiatesta. Seduta e schienale imbottiti e rivestiti in pelle. Uno sgabello per uso domestico che risponde alle attuali tendenze d'arredo.

Tabouret en métal réglable en hauteur. Assise et dossier rembourrés et revêtus en cuir. Un tabouret pour un usage domestiques, qui répond parfaitement à les actuelles tendance de design.

Yumi is a height-adjustable stool with metal base and footrest. Seat and back are filled up and covered with leather. It's a stool for domestic use that responds to the actual furniture trend.



Base / Piétement / Base: Cromo lucido M05

Seduta / Assise / Seat: pelle, cuir, leather - Nero JP11, Bianco JP30

TAUBOURETS / STOOLS
SGABELLI



| Form

stool

design_Studio Sv

La forma asimmetrica dello sgabello Form si distingue per il suo carattere informale. La struttura in metallo è regolabile in altezza, mentre la seduta in poliuretano morbido garantisce comfort e vivacità.

La forme asymétrique du tabouret Form se caractérise pour son caractère informel. La structure en métal est réglable en hauteur et son assise en polyuréthane assure toujours le confort et vivacité.

The asymmetrical shape of Form stool distinguishes itself for its inform character. The metal height-adjustable structure is matched with a soft polyurethane seat that guarantees comfort and liveliness.

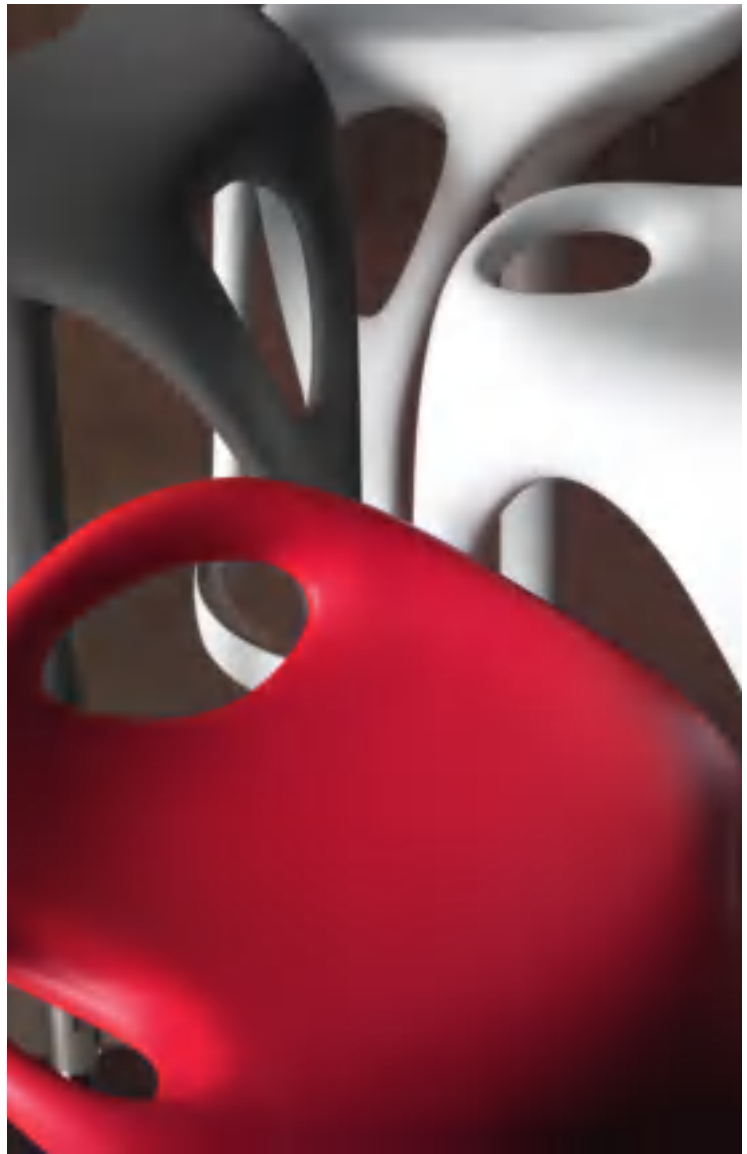

Base / Piétement / Base: Cromo lucido M05

Seduta / Assise / Seat: poliuretano morbido, polyuréthane souple, soft polyurethane - Grigio S04, Rosso S03, Bianco S01

TAUBOURETS / STOOLS
SGABELLI



Momo

stool

design_Arter&Citton

Lo sgabello Momo si presenta con la seduta in poliuretano morbido dalla forma che ricorda un soffice cuscino. La struttura di sostegno in metallo cromo con poggipiedi è disponibile nella versione fissa o regolabile in altezza.

Le tabouret Momo est ici avec une assise en polyuréthane qui semble un souple coussin. La structure en métal chromé avec repose-pieds est disponible en version fixe ou réglable en hauteur.

Momo stool is presented with a soft polyurethane seat with a shape that reminds of a soft pillow. The sustaining chromed metal structure with footrest is available in fixed or height-adjustable version.



Base / Piétement / Base: Cromo lucido M05

Seduta / Assise / Seat: poliuretano morbido, polyuréthane souple, soft polyurethane - Rosso S03, Nero S02

TAUBOURETS / STOOLS
SGABELLI



Base / Piétement / Base: Cromo lucido M05

Seduta / Assise / Seat: poliuretano morbido, polyuréthane souple, soft polyurethane - Nero S02, Rosso S03

Sedie, poltroncine, sgabelli

chaises, fauteuils, tabourets
chairs, armchairs, stools



_Yoshi Wood chair
page 94

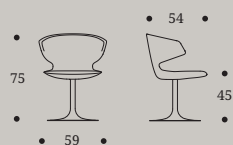

_Yoshi chair
page 96

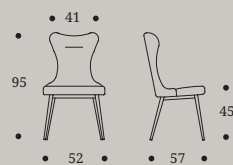

_Minnie chair
page 100

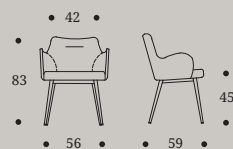

_Minnie Soft armchair
page 104

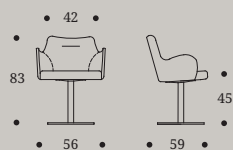

_Minnie Swivel Soft armchair
page 106

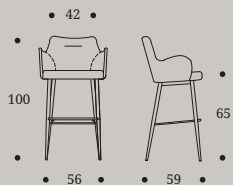

_Minnie Fix stool
page 110

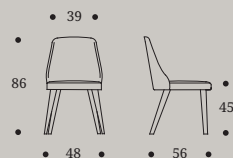

_Jolly chair
page 114

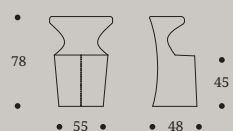

_Desy armchair
page 192

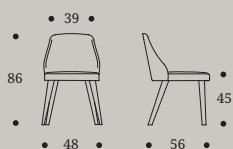

_ Jolly Soft chair
page 118

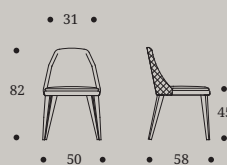

_ Polly Wood chair
page 140

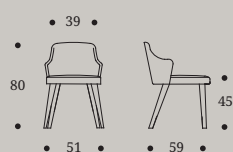

_ Jolly armchair
page 122

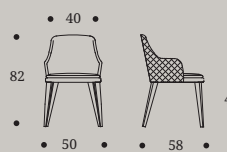

_ Polly Wood armchair
page 146

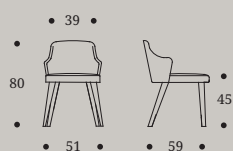

_ Jolly Soft armchair
page 124

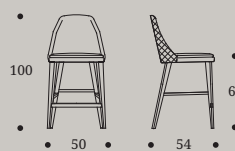

_ Polly Wood stool
page 150

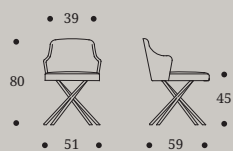

_ Jolly Cross Soft armchair
page 128

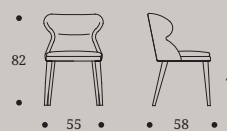

_ Fenice armchair
page 154

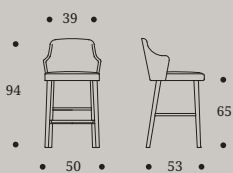

_ Jolly stool
page 130

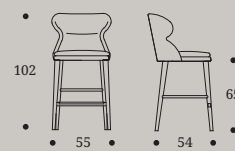

_ Fenice stool
page 158

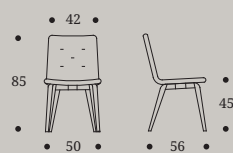

_ Maya Wood chair
page 132

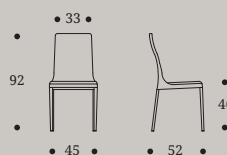

_ Clery chair
page 162

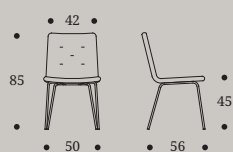

_ Maya chair
page 134

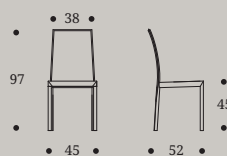

_ Rosa chair
page 164

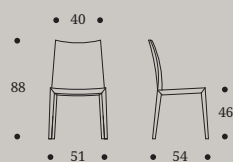

_ Flora chair
page 182

Sedie, poltroncine, sgabelli

chaises, fauteuils, tabourets
chairs, armchairs, stools

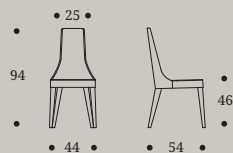

Mila chair
page 166

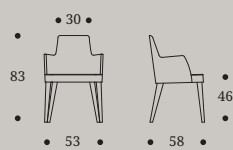

Mila armchair
page 167

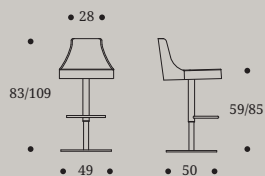

Mila stool
page 168

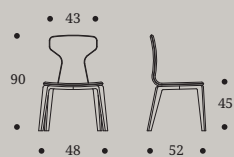

Monika chair
page 170

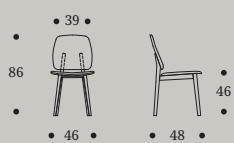

Luxi chair
page 172

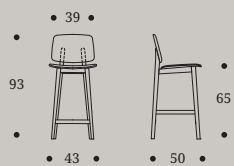

Luxi stool
page 174

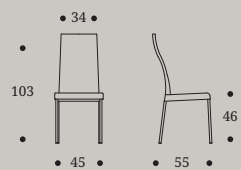

Marilyn chair
page 176

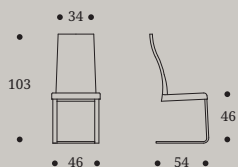

Slim chair
page 178

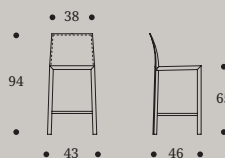

Romy stool
page 196

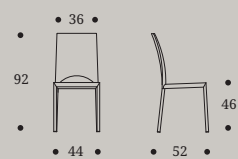

Mary chair
page 180

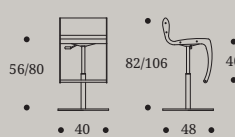

Yumi stool
page 198

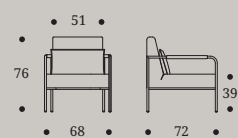

Liza armchair
page 184

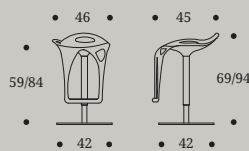

Form stool
page 200

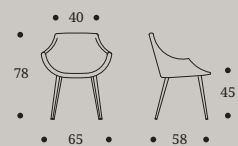

Rosy armchair
page 186



Momo 66 Fix stool
page 202

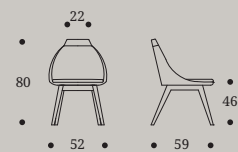

Desire armchair
page 188



Momo 76 Fix stool
page 202

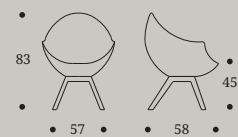

Jane Fix armchair
page 190

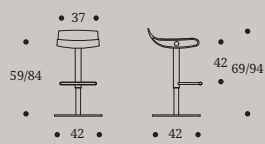

Momo Swivel stool
page 203

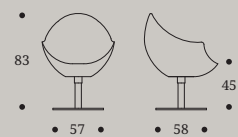

Jane Swivel armchair

—

*BUFFETS
/ SIDEBOARDS*

COM
PAR
ITALIAN DESIGN

| MADIE

| Dama

sideboard

design_Andrea Lucatello

Nella combinazione di più elementi e materiali, Dama si esprime attraverso il disegno esclusivo dell'anta che gioca con le inclinazioni creando piacevoli effetti tridimensionali, eseguiti con maestria e rigore formale. La madia Dama si compone di tre ante laccate, mentre il profilo inclinato che indica l'apertura vive di un legno massello estremamente tattile. Al top una preziosa ceramica completa l'opera degna del suo nome.



Dans ses combinaisons de multiples éléments et matériaux, Dama s'exprime à travers le design exclusif de la porte qui joue avec ses inclinaisons et crée des effets tridimensionnels agréables, exécutés avec maîtrise et rigueur formelle. Le buffet Dama est composé de trois portes laqué, tandis que le profil incliné indiquant l'ouverture est en bois massif extrêmement tactile. Au sommet, une céramique précieuse, brillante qui complète une œuvre digne de ce nom.

With a combination of elements and materials, Dama expresses itself through an exclusive doors design that plays with inclines creating pleasant, three-dimensional effects. Dama sideboard is composed of three doors in lacquered, while the inclined profile, showing the opening, lives off solid walnut wood. On top, a precious polished ceramic completes the worth-of-its-name artwork.

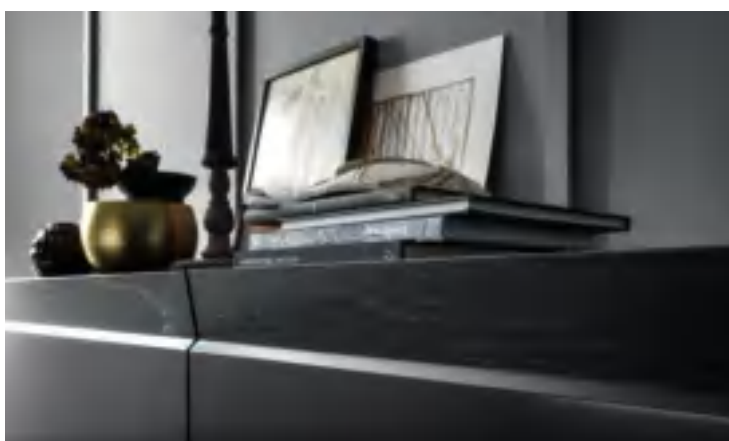

Struttura a ante / Structure et portes / Body and doors:

laccato, laqué, lacquered - Antracite metallizzato L05

Cornice / Cadre / Frame: laccato, laqué, lacquered - Antracite metallizzato L05

Piano / Plateau / Top: ceramica, céramique, ceramic - Noir Desire Lucido K04

BUFFETS / SIDEBOARDS

MADIE







Sedia JOLLY

Gambe e seduta / Pieds et assise / Legs and seat: tessuto, tissu, fabric Karina - Grigio platino TK24

Profilo / Profile / Piping: ecopelle, eco-cuir, eco-leather - Testa di moro EB57



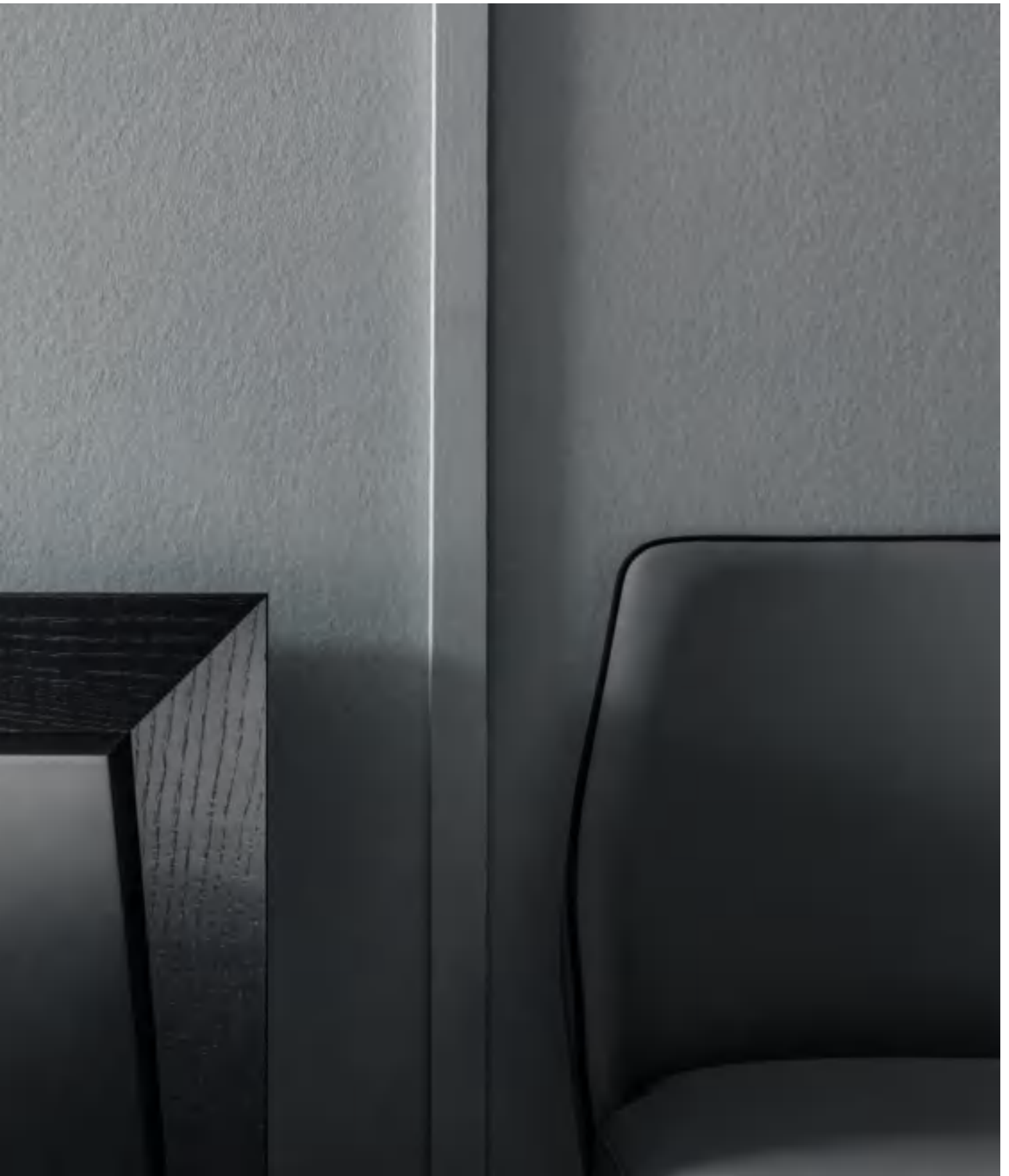

| Dama_sideboard





BUFFETS / SIDEBARDS

MADIE

Ermes

sideboard

La madia Ermes assottiglia i suoi fianchi e riprende le stesse linee curve nella definizione dei cassetti centrali. La struttura in Noce canaletto si staglia dolcemente oltre il top, incorniciandolo con un'alzatina sagomata. Le ante laccate sabbia mantengono i toni caldi del legno.

design_Riccardo Buscato

Le buffet Ermes a des côtés minces et des lignes arrondies dans les tiroirs au milieu. La structure en Noyer canaletto caractérise les deux côtés, le dos et la partie supérieure. Les portes laquées en couleur sable soulignent la chaleur du bois.

Ermes cupboard wears thin and get back with same bent lines in the definition of the central drawers. The walnut wood structure stands out delicately on the back, framing the top with a molded lift. The sand lacquered doors keep the warm tones of wood.



Struttura e cassetti / Structure et tiroirs / Body and drawers: legno impiallacciato, bois placage, veneered wood - Noce canaletto W10
Ante / Portes / Doors: laccata, laqué, lacquered - Sabbia L70

BUFFETS / SIDEBARDS

MADIE









| Athena

sideboard

| design_Andrea Lucatello

La madia Athena si presenta in maniera raffinata e briosa allo stesso tempo; con eleganza entra nei living più ricercati come anche negli ambienti più informali. La struttura interamente laccata viene esaltata dal prezioso profilo in ceramica delle ante creando così un vivace gioco di forme.

Le buffet Athena est élégante et éclectique en même temps: parfait pour les ambiances les plus sophistiqués et même pour les plus informels. La structure complètement laquée est enrichie par l'élément en céramique des portes, pour un dynamique jeu de formes.

Athena sideboard presents itself in a refined and lively way at the same time; with elegance it enters both into the most cherished livings and into the most informal spaces. The entirely lacquered structure is enhanced by the precious ceramic detail of the doors, creating a dynamic game of shapes.

Struttura / Structure / Body: laccato, laqué, lacquered - Antracite metallizzato L05
Ante / Portes / Doors: ceramica, céramique, ceramic - Pietra Grey Opaco K16

Piero Manzoni 1933-1963

RICHARD SERRA DISEGNI 1960
ZEICHNUNGEN 1970

APRES LO SGUARDO DELL'ARTISTA

espressioni vitali del negativo







| Optik

sideboard

Optik è un complemento d'arredo davvero unico, le sue linee convergono nei punti esterni della madia formando un effetto ottico esclusivo realizzato da intarsi serigrafici. Composta da tre ante si presenta come un quadro astratto fortemente caratterizzante.

design_Andrea Lucatello

Optik est un accessoire d'ameublement tout à fait unique. Ses lignes convergent vers les points extérieurs du buffet, créant un effet optique particulièrement exclusif créé par des marqueteries en sérigraphie. Composé de trois portes, il se présente comme une peinture abstraite fortement caractérisante.

Optik is a unique occasional complement. Its lines converge on the external point of the sideboard, creating an exclusive optical effect realized by screen printed inlays. Composed of three doors, Optik looks like an abstract picture.

The metal structure that supports the sideboard follows with dynamism the drawing of the doors pursuing its inclination and its formal balance.

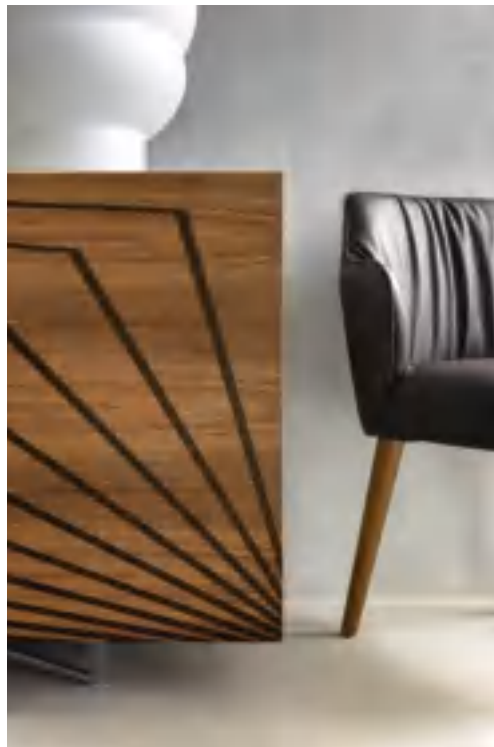

Struttura / Structure / Body: laccata, laqué, lacquered - Sabbia L70

Ante / Portes / Doors: legno impiallacciato, bois placage, veneered wood - Noce canaletto W10

BUFFETS / SIDEBOARDS

MADIE



| Optik_sideboard









Poltroncina JOLLY SOFT

Gambe / Pieds / Legs: legno massiccio, bois massif, solid wood - Frassino canaletto W60

Seduta / Assise / Seat: pelle, cuir, leather - Testa di moro JP44

| Optik_sideboard





BUFFETS / SIDEBARDS

MADIE

Vanity

sideboard

design_Roberto Pravato

La forma ricercata della madia Vanity esalta l'elemento centrale sporgente composto da due cassetti in finitura Noce canaletto abbinati al top. Le ante e i fianchi laccati sabbia riflettono la luce con le loro diverse inclinazioni, in un gradevole ventaglio di tonalità.

Le design raffiné du buffet Vanity exalte l'élément central composé par deux tiroirs en finition noyer canaletto. Les portes et les côtés laqués sable reflètent la lumière avec leur différentes inclinations, pour un agréable gamme des tonalités.

The sophisticated shape of Vanity cupboard glorifies the central element composed of two drawers in walnut wood finish combined with the top. The sand lacquered doors and sides reflect the light with different inclinations, resulting in a pleasant range of tones.



Struttura e ante / Structure et portes / Body and doors:
laccata, laqué, lacquered - Sabbia L70
Piano e cassetti / Plateau et tiroirs / Top and drawers:
legno impiallacciato, bois placage, veneered wood - Noce canaletto W10

BUFFETS / SIDEBARDS

MADIE







| Vanity_sideboard





Madie

buffets, sideboards

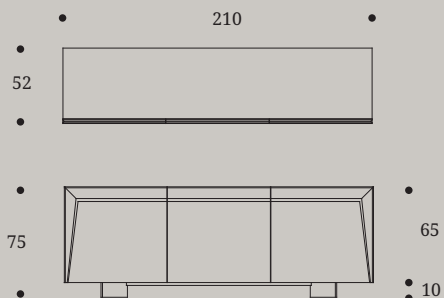

Dama sideboard
page 210

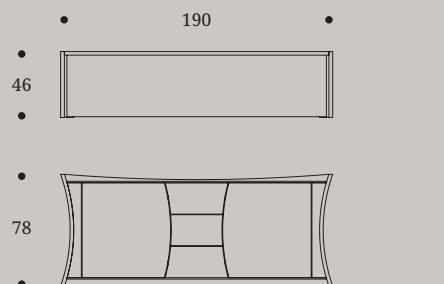

Ermes sideboard
page 218

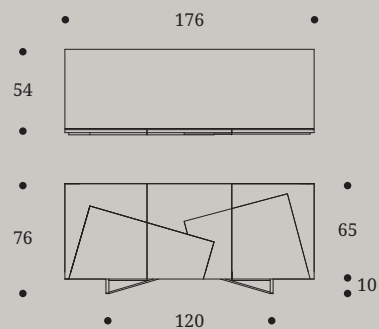

Athena sideboard
page 222

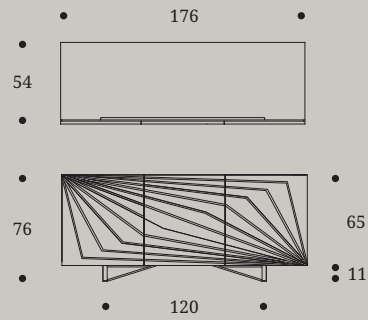

Optik sideboard
page 228

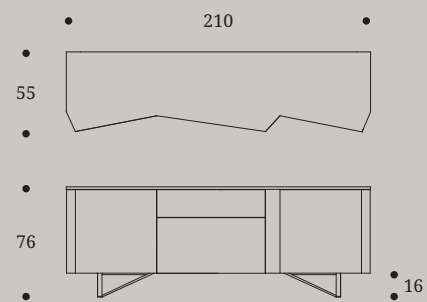

Vanity sideboard
page 236

—

*TABLE BASSE
/ COFFEE TABLES*

COM
PAR
ITALIAN DESIGN

| TAVOLINI

| Trendy

coffee table

I tavolini Trendy si presentano come solide forme create dalla maestria di abili artigiani vetrai. La loro struttura liscia per i salotti più sobri o bocciardata per gli ambienti più ricercati, si abbina a diversi stili di arredamento grazie alla raffinatezza delle colorazioni Fumé e Bronzo.

design_Tosca Design

Les tables Trendy se présentent comme le résultat du savoir-faire d'habiles maîtres verriers. Leur structure lisse, pour les séjours le plus sobres, ou bouchardée, pour les pièces les plus recherchés, se décline aux différents styles d'ameublement grâce à l'élégance des couleurs Fumé et Bronze.

Trendy coffee tables stand out as solid forms created by the mastery of skilled glass artisans. Its smooth structure fits perfectly into the most sober salons, whereas its bush-hammered version suits the most refined atmosphere. Its finishes, Fumé or Bronzo, allows the coffee table to find room in different furnishing styles.

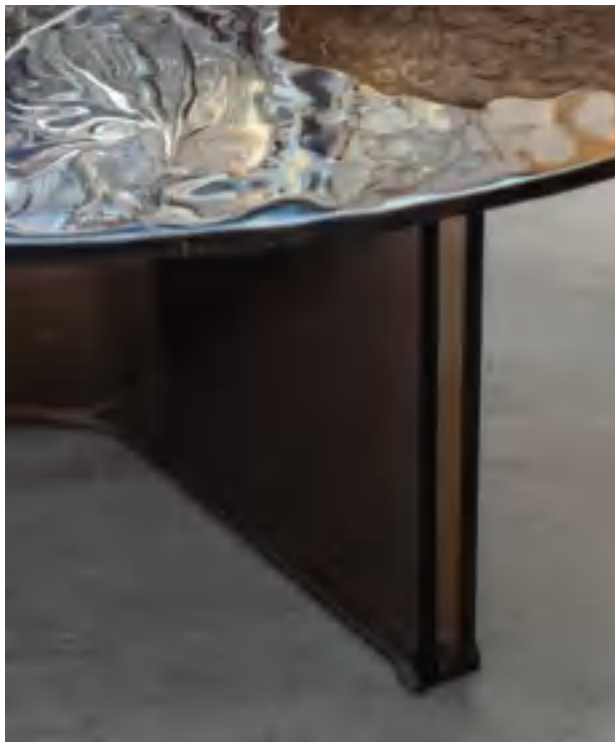

Struttura / Structure / Body: vetro, verre, glass - Bronzo liscio G11
Piano / Plateau / Top: vetro, verre, glass - Bronzo bocciardato G13



TABLE BASSE / COFFEE TABLES

TAVOLINI



H.27 Ø 75 / H.35 Ø 60

Struttura / Structure / Body: vetro, verre, glass - Bronzo liscio G11

Piano / Plateau / Top: vetro, verre, glass - Bronzo bocciardato G13



H.45 Ø 45

Struttura e piano / Structure et plateau / Body and top: vetro, verre, glass - Fumé bocciardato G14

Rio

coffee table

Il tavolino Rio attira l'attenzione degli ospiti grazie al pregiato piano in ceramica. In entrambe le versioni, il ripiano posizionato sotto al top principale è un astuto sistema per recuperare spazio prezioso nella zona giorno.

design_Andrea Lucatello

La table Rio est au top dans sa version en céramique. Dans les deux hauteurs disponibles il y a aussi un deuxième plateau pour gagner de la place dans le séjour.

Rio coffee table captures the attention of the guests thanks to its precious ceramic top. In both heights it is endowed with a second shelf located under the main top, a smart system to recover precious space in the living room.



H.36 / H.55

Base / Piétement / Base: verniciato, verni, coated - Grafite goffrato M11

Piano / Plateau / Top: ceramica, céramique, ceramic - Calacatta Gold Lucido K13

TABLE BASSE / COFFEE TABLES

TAVOLINI



| Rio_coffee table





| Club

coffee table

I tavolini tondi Club con base in metallo sono un passe-partout della zona giorno, disponibili in varie dimensioni e finiture dei piani in ceramica. Versatili e di tendenza sono un complemento d'arredo irrinunciabile.

design_Com.p.ar

Les tables rondes Club avec ses piètements en métal sont un passe-partout du séjour, disponibles dans plusieurs dimensions et finitions des plateaux en céramique. Polyvalentes et à la mode, ces sont un complément essentiel.

The round tables Club, with their metal base, are a passe-partout of the living room. They are available in many dimensions and finishes of ceramic tops. Versatile and trendy, they are an undeniable piece of furniture.



TABLE BASSE / COFFEE TABLES

TAVOLINI



Base / Piétement / Base: verniciato, verni, coated - Grafite goffrato M11

Piano / Plateau / Top H.27 Ø 60 cm: ceramica, céramique, ceramic - Fokos Terra K02

Piano / plateau / Top H.35 Ø 75 cm: ceramica, céramique, ceramic - Diamond Cream Lucido K06

Piano / Plateau / Top H.45 Ø 45 cm: ceramica, céramique, ceramic - Emperador Opaco K20



Cross

coffee table

design_Com.p.ar

L'intersezione delle gambe della poltroncina Jolly Cross trova applicazione anche nel tavolino creando un legame unico tra questi due oggetti di arredo. L'abbinamento con i piani tondi in ceramica diventa espressione di un gusto ricercato e di classe.

L'intersection des pieds du fauteuil Jolly Cross se décline parfaitement à ce produit, en créant une liaison unique entre ces deux objets. La combinaison avec les plateaux ronds en céramique est synonyme de classe et recherche.

The crossing base of Jolly Cross armchair finds application also in its coffee table version, creating a unique connection between these two furniture objects. The match with ceramic round tops become expression of a cherished and classy taste.



Base / Piétement / Base:

verniciato, verni, coated - Grafite goffrato M11

Piano / Plateau / Top H.27 Ø 60 cm:

ceramica, céramique, ceramic - Pietra di Savoia Perla K12

Piano / Plateau / Top H.35 Ø 45 cm:

ceramica, céramique, ceramic - Pietra di Savoia Antracite K11





| **Square**
coffee table

| design **Andrea Lucatello**

Gli spessori ridotti e le linee perpendicolari fanno di Square un tavolino dallo spiccato carattere moderno, le finiture colorate del piano in vetro contribuiscono a rendere questo complemento d'arredo interessante e versatile.

La petite épaisseur et les lignes perpendiculaires rendent Square une table moderne. Les finitions colorées du plateau en verre rendent ce produit intéressant et polyvalent.

The reduced thickness and the perpendicular lines give to the Square table a pronounced modern character. The coloured finishes of the glass top help making this piece of furniture interesting and versatile.

Base / Piétement / Base: verniciato, verni, coated - Tortora opaco M12
Piano / Plateau / Top: vetro, verre, glass - Tortora acidato G05

Base / Piétement / Base: verniciato, verni, coated - Grafite goffrato M11
Piano / Plateau / Top: vetro, verre, glass - Cenere acidato G10

TABLE BASSE / COFFEE TABLES

TAVOLINI





| **Birdy**
coffee table

| design_**Com.p.ar**

Innumerevoli sono le combinazioni possibili tra dimensioni e colori nel tavolino Birdy. Il piano in ceramica tondo poggia leggero sulla base in metallo composta da elementi inclinati, con giochi grafici e cromatici di grande effetto.

Les possibles combinaisons des couleurs et dimensions concernant la table Birdy sont nombreux. Le plateau rond en céramique s'appuie sur un piétement en métal, caractérisé par des éléments inclinés, avec des jeux d'image et des couleurs à grand effet.

Table Birdy has countless possible matches between dimensions and colours. The round ceramic top lies softly in the metal base that is composed of sloped elements, with graphical and chromatic games.

H.35 Ø 75

Base / Piétement / Base: verniciato, verni, coated - Grafite goffrato M11
Piano / Plateau / Top: ceramica, céramique, ceramic - Oxide Nero K09

H.45 Ø 45 / H.55 Ø 45

Base / Piétement / Base: verniciato, verni, coated - Bianco goffrato M24

Piano / Plateau / Top: ceramica, céramique, ceramic - Fokos Terra K02, Fokos Piombo K03

TABLE BASSE / COFFEE TABLES

TAVOLINI



Smart coffee table

design_Andrea Lucatello

Nel piano ovale del tavolino Smart convivono due diverse finiture, per chi ama arredare con luce e colore.

La struttura in metallo separa e unisce nel contempo le due metà in un gioco di contrasti che dà vita all'ambiente circostante.

Dans le plateau ovale de la table Smart il y a deux différentes finitions, pour ce qui aime les jeux des lumières et couleurs. La structure en métal sépare et combine au même temps les deux moitiés, pour un jeu des contrastes qui donne de l'énergie à l'environnement.

In the oval top of table Smart two different finishes coexist, for those who love furnishing with light and colour. The metal base divides and reunites at the same time the two halves in a game of contrasts that give birth to the surrounding space.

Base / Piétement / Base: verniciato, verni, coated -
Grafite goffrato M11

Piano / Plateau / Top: ceramica, céramique, ceramic -
Pietra di Savoia Antracite K11 + Pietra di Savoia Perla K12

Poltroncina ROSY

Gambe / Pieds / Legs: verniciate, verni, coated - Nero goffrato M20

Seduta / Assise / Seat: ecopelle, eco-cuir, eco-leather Nabuk -
Grigio chiaro NB09





| **Smart_coffee table**



Base / Piétement / Base: verniciato, verni, coated - Bronzo goffrato M19
Piano / Plateau / Top: legno impiallacciato, bois placage, veneered wood - Noce canaletto W10 +
laccato, laqué, lacquered - Bronzo metallizzato L71

TABLE BASSE / COFFEE TABLES

TAVOLINI

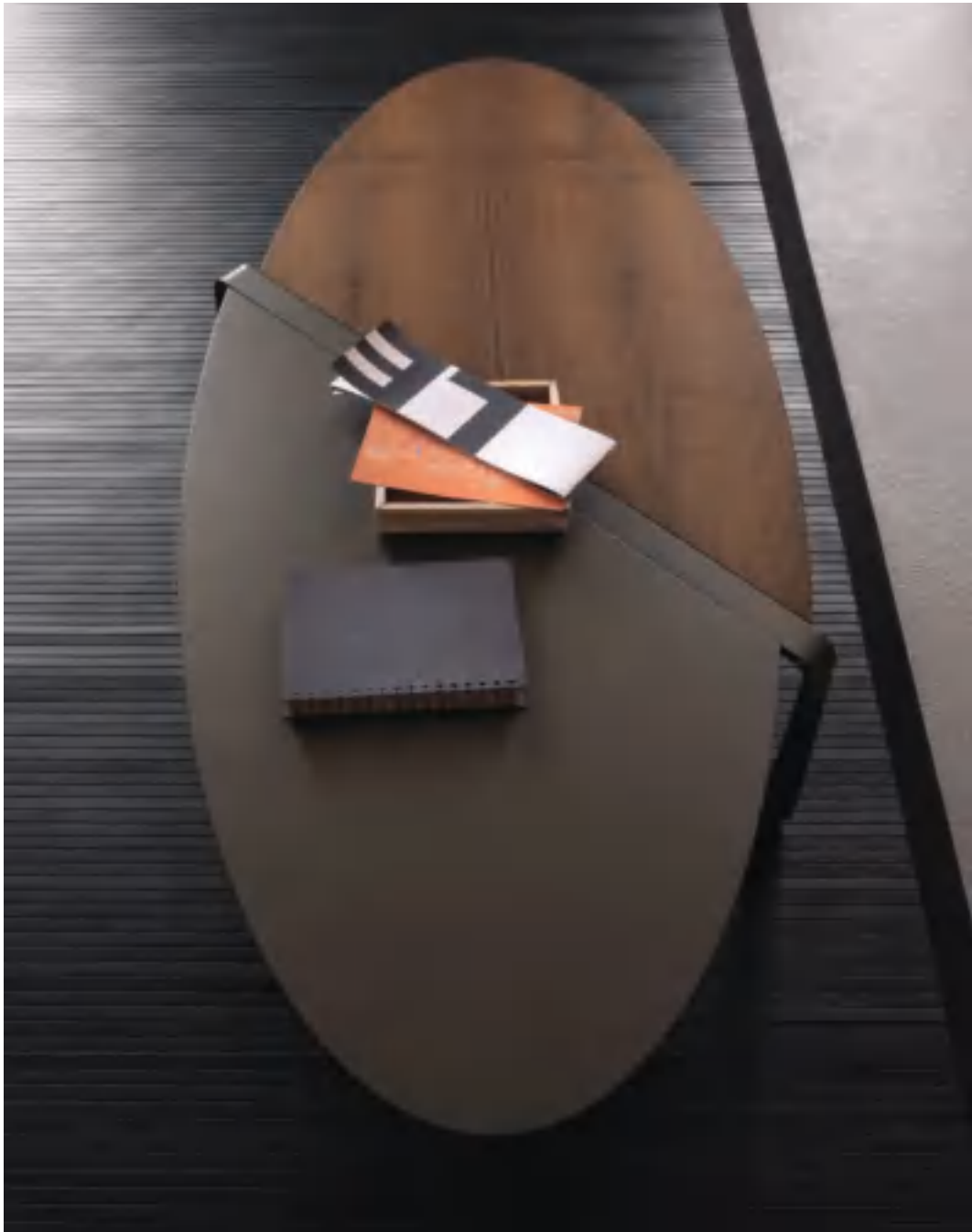

| Billy

coffee table

design **Andrea Lucatello**

Billy, tavolino dalle numerose funzioni, si distingue per il suo aspetto allegro e giocoso, e ben si adatta ad essere collocato in ogni angolo della casa. La finitura in polietilene lo rende particolarmente pratico e facile da pulire. Il piano superiore bicolore rivela un vano dove riporre piccoli oggetti da tenere sempre a portata di mano.

Billy, table aux nombreuses fonctions, se distingue pour son aspect joyeux et s'adapte parfaitement à toutes les pièces de la maison. La finition en polyéthylène la rend pratique et facile à nettoyer. Le plateau bicolore cache un compartiment où ranger des petits objets à portée de main.

Billy, coffee table with thousand functions, stands out for its cheerful and playful aspect and well suits to be collocated in every corner of your home. The polyethylene finish makes it very practical and easy to clean. The bicolor top reveals a compartment where store small objects to keep always at hand.



Struttura / Structure / Body: polietilene, polyéthylène, polyethylene -
Bianco Z01, Tortora Z03, Nero Z02, Rosa Z09, Verde Z05, Azzurro Z07

TABLE BASSE / COFFEE TABLES

TAVOLINI



BILLY LAMP

Struttura / Structure / Body: polietilene, polyéthylène, polyethylene - Bianco Z01

| Billy Lamp

coffee table

Billy Lamp è un versatile punto luce multicolore che illumina gli ambienti in maniera discreta e soffusa. La ricarica di 24 ore permette di trasferirlo da una stanza all'altra in piena comodità.

Billy Lamp est une lampe multicolore qui éclaire doucement et avec discrétion. La charge de 24 heures permet de la déplacer facilement de pièce en pièce.

Billy Lamp is a versatile and multicolour light source, which illuminates spaces in discreet and suffused way.

The 24 hours recharge allows to move it from a room to one other in full comfort.



Piano / Plateau / Top: pvc bicolore Bianco/Noce

TABLE BASSE / COFFEE TABLES

TAVOLINI



Struttura / Structure / Body: polietilene, polyéthylène, polyethylene - Bianco Z01

| Boat

coffee table

La perfetta brillantezza del vetro, che come l'acqua riflette la luce, si ritrova nel piano del tavolino Boat, sostenuto da una solida base che si restringe a terra ancorandosi ad una stabile zavorra. Disponibile in due altezze si accosta agevolmente al divano.

design_Pierpaolo Zanchin

La parfaite luminosité du verre, qui reflète la lumière comme l'eau, se trouve aussi dans le plateau de la table Boat. La stabilité est toujours assurée par un piétement, qui se réduit au sol. Cette table est disponible dans deux hauteurs et elle se combine parfaitement au canapé.

The perfect brilliance of the glass, which reflects light like water, is found in the top of table Boat.

The table is sustained by a solid base, it narrows to the floor and then grasps on a ballast that confers extreme stability. It is available in two different heights and can be easily put near the sofa.



Base / Piétement / Base: verniciato, verni, coated - Bianco gofrato M24
Piano / Plateau / Top: vetro, verre, glass - Cenere acidato G10

TABLE BASSE / COFFEE TABLES

TAVOLINI



Base / Piétement / Base: verniciato, verni, coated - Grafite goffrato M11
Piano / Plateau / Top: vetro, verre, glass - Bianco acidato G04

| Tablet coffee table

Un punto d'appoggio attrezzato per l'utilizzo dei dispositivi digitali è la soluzione ideale per le esigenze domestiche attuali. Il supporto Tablet regolabile in altezza con base in metallo laccata e piano in tinta, consente di usare correttamente e riporre ogni oggetto, mantenendo in ordine anche i cavi necessari.

design_Studio SV

Un système de soutien pour utiliser au mieux les appareils digitaux: la meilleure solution pour les besoins d'aujourd'hui. Le support Tablet est réglable en hauteur, avec un piétement en métal verni et avec un plateau ton sur ton. Parfait aussi pour ranger les câbles et assurer l'ordre après chaque utilisation.

A support point equipped for the use of digital device is the ideal solution for the actual domestic needs. The Tablet support, adjustable in height with a metal lacquered base and matched top, allows the correct usage of every object and its keeping.



Base / Piétement / Base: verniciato, verni, coated - Bianco gofrato M24
Piano / Plateau / Top: bianco

Base / Piétement / Base: laccate, laquées, lacquered - Tortora opaco M12
Piano / Plateau / Top: tortora



Tavolini

table basse, coffee tables

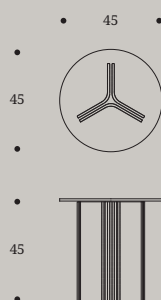
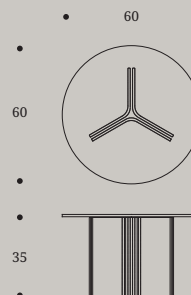
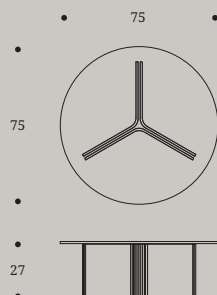

_Trendy coffee table
page 246

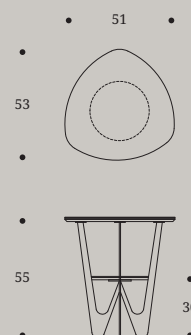
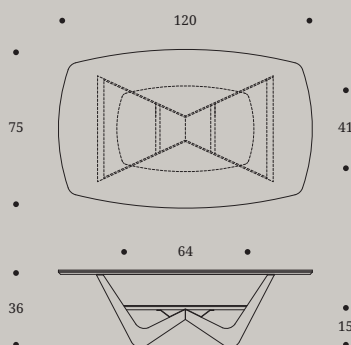

_Rio coffee table
page 250

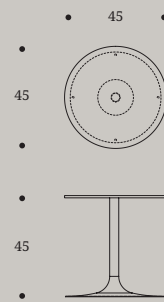
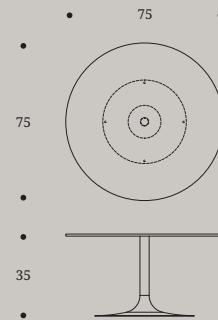
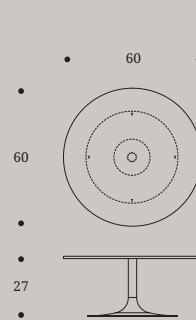

Club coffee table
page 254

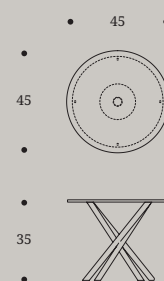
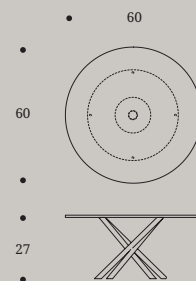

Cross coffee table
page 256

Tavolini

table basse, coffee tables

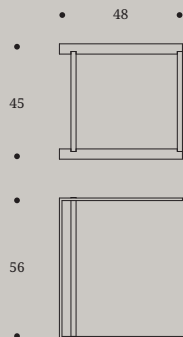

—Square coffee table
page 258

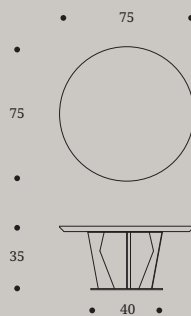
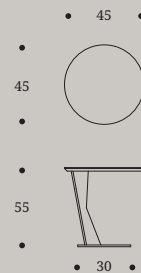
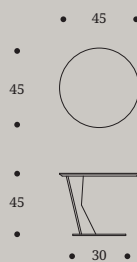

—Birdy coffee table
page 260

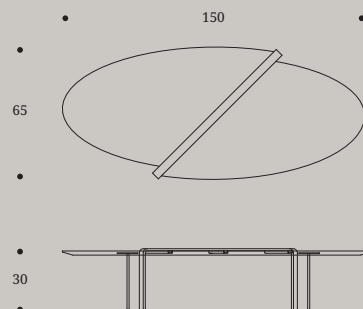

—Smart coffee table
page 262

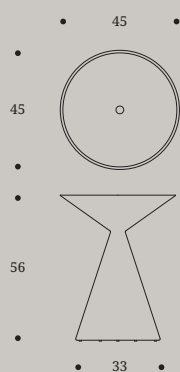

Billy coffee table
page 266

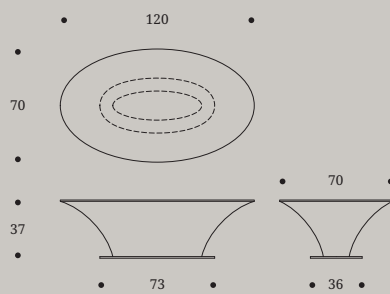
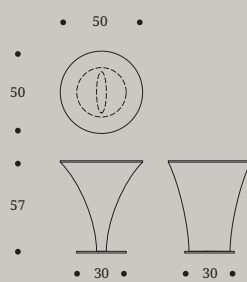

Boat coffee table
page 270

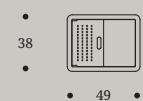
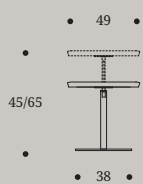

Tablet coffee table
page 272

—

*CONSOLES ET BUREAU
/ CONSOLE
AND WRITING DESK*

COM
PAR^I

ITALIAN DESIGN

CONSOLLE E SCRITTOIO

Reverse

console

design_Andrea Lucatello

Tutto è a portata di mano e in ordine con la console Reverse. I ripiani su due altezze si completano con il cassetto, apribile attraverso l'incavo che lo incornicia e che prosegue nei profili di tutta la console. Il gioco di incastri è riproposto nella specchiera Florence, dove una cornice ideale viene ruotata e rappresentata con un inserto in finitura laccata.

Tout est bien rangé dans la console Reverse. Les plateaux sur deux hauteurs sont complétés par un tiroir, ouvrable par la prise qui encadre toute la console. On peut retrouver ce jeu même dans le miroir Florence, où le cadre est tourné et constitué par un insert laqué.

Everything is at your fingertips and ordered with the Reverse console. The tops on two heights complete each other with the drawer that can be opened through the hollow that frames it and that continues for the entire edging of the console. The shape sorter game is again proposed in the Florence wall mirror, where an ideal frame is rotated and represented with a lacquered insert.

Specchiera FLORENCE

Struttura / Structure / Body: laccata, laqué, lacquered - Sabbia L70

Console REVERSE

Struttura / Structure / Body: laccata, laqué, lacquered - Sabbia L70, Bronzo metallizzato L71

CONSOLES / CONSOLE
CONSOLLE







CONSOLES / CONSOLE
CONSOLLE

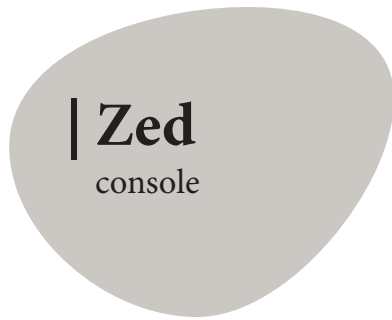

| Zed

console

design_Andrea Lucatello

Il tratto caratteristico della console Zed è la base slanciata, dalla quale emerge un profilo in noce che si lega al top con estrema naturalezza. Le linee pulite conferiscono un'immagine di forte stabilità, grazie anche all'inserto laccato bronzo. La console diventa così un mobile di pregio estremamente versatile.

Le trait caractéristique de la console Zed est le piétement élancé, avec son élément en noyer qui se combine parfaitement au plateau. Les lignes nettes et simples donnent une image de forte stabilité, grâce à l'insert bronze. La console devient un meuble de valeur et polyvalent.

The characteristic line of the Zed console is noted for its slender base, from which emerges a walnut element that links itself to the top with extremely naturalness. The clean lines and the bronze lacquered insert confer the table an image of strong stability. In this way the console becomes an extremely versatile piece of furniture.

Specchiera FLORENCE

Struttura / Structure / Body: laccata, laqué, lacquered - Sabbia L70

Console ZED

Base / Piétement / Base: legno impiallacciato, bois placage, veneered wood - Noce canaletto W10 + laccato, laqué, lacquered - Bronzo metallizzato L71
Piano / Plateau / Top: legno impiallacciato, bois placage, veneered wood - Noce canaletto W10

CONSOLES / CONSOLE
CONSOLLE





| **Pad**
writing desk

| design_ **Dario Delpin**

Piano d'appoggio, mensola e cassetto: non manca nulla allo scrittoio Pad che, nonostante le sue misure contenute, assolve in modo impeccabile al suo ruolo di zona studio.

Plateau, étagère et tiroir: le bureau Pad a tout le nécessaire, malgré ses petites dimensions. Parfaite comme bureau également.

Support top, shelf and drawer: nothing misses in the Pad writing desk that, despite its contained dimensions, fulfills in a flawless role the study space.

Base e piano / Piétement et plateau / Base and top:
legno impiallacciato, bois placage, veneered wood - Noce canaletto W10



| Pad_writing desk

Il piano d'appoggio, corredato dal sottomano in cuoio rigenerato, rivela al suo interno un comodo vano contenitore.

Le plateau est complété par un sous-main en cuir et un espace de rangement caractérise son intérieur.

The support top, equipped with a regenerated leather pad, reveals a convenient glove compartment on the inside.

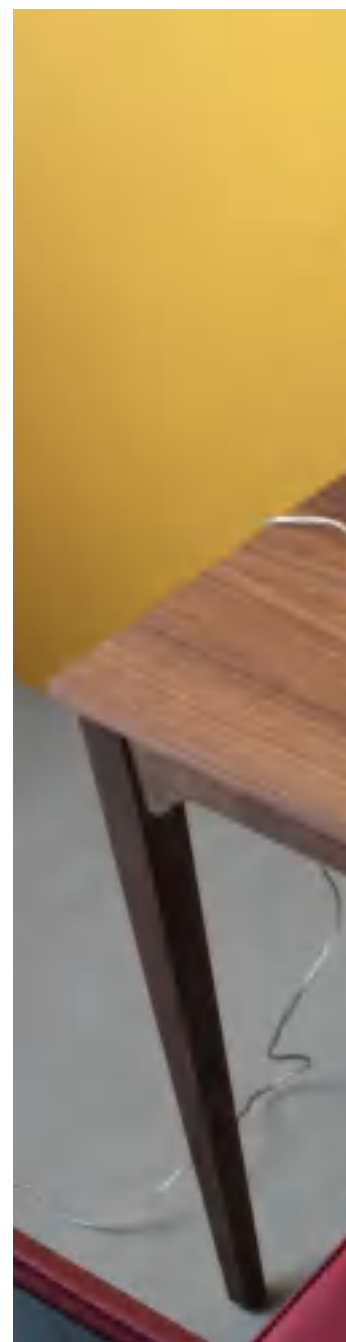

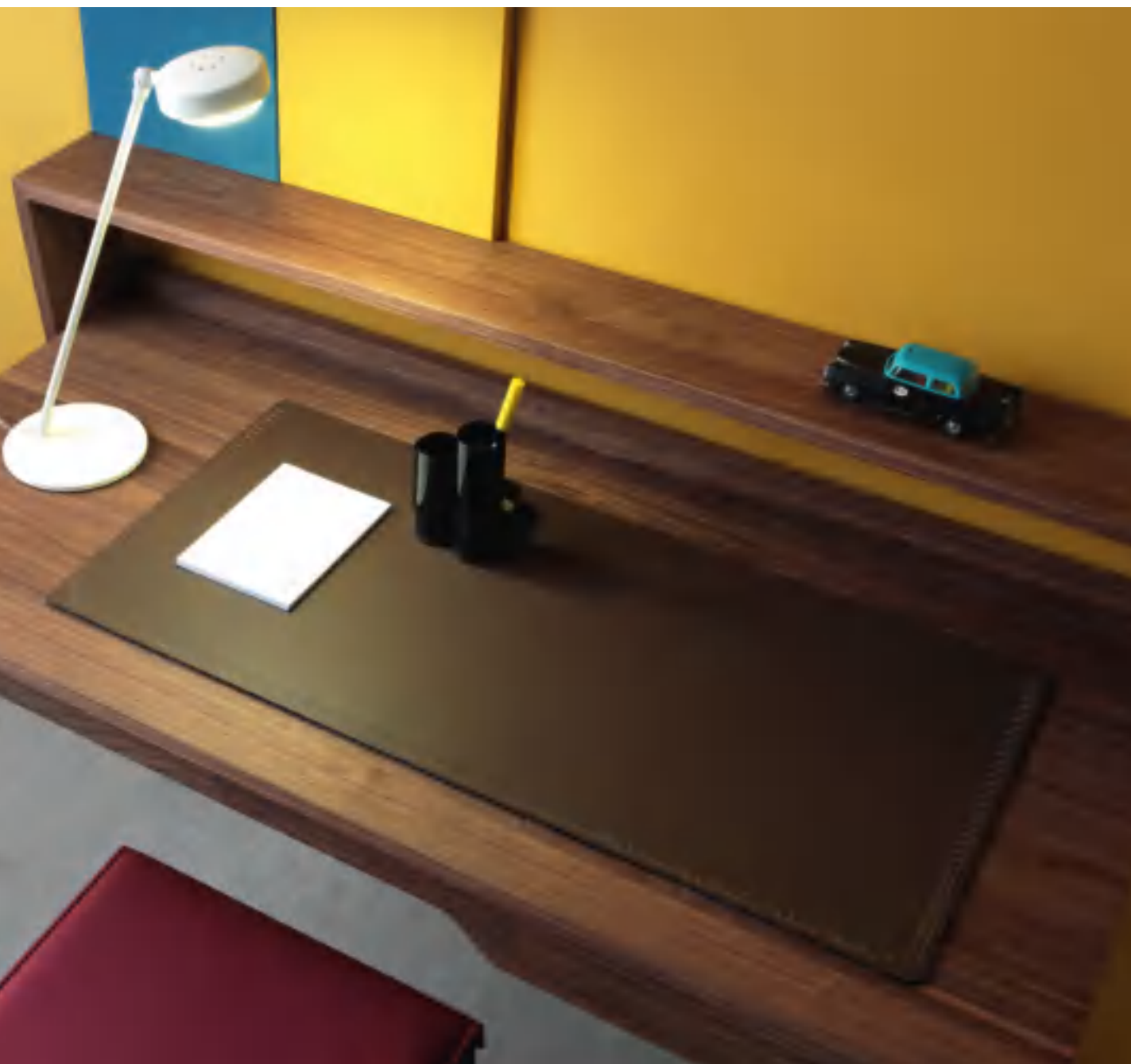

Base / Piétement / Base: legno impiallacciato, bois placage, veneered wood -
Noce canaletto W10

Piano / Plateau / Top: legno impiallacciato, bois placage, veneered wood -
Noce canaletto W10 + cuoio rigenerato, cuir régénéré, regenerated leather - Testa di moro RC08

| DIMENSIONI
DIMENSIONES
DIMENSIONS

| Console e scrittoio

consoles et bureau, console and writing desk

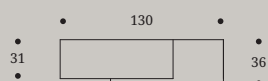
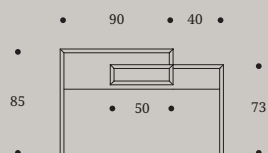

Reverse console
page 280

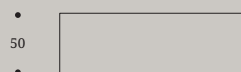
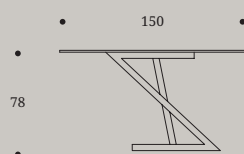

Zed console
page 284

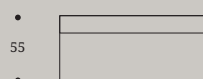
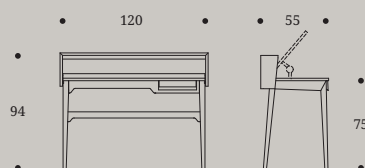

Pad writing desk
page 286

—

MIROIRS
/ MIRRORS

COM
PAR
ITALIAN DESIGN

| SPECCHIERE



Luxor
mirror

Sfruttare ogni superficie e ogni spazio in modo elegante e sofisticato: due specchi racchiudono una libreria e danno forma a Luxor, una piramide multitasking, dove lo specchio prende una sfumatura color bronzo.

design_Tosca Design

Profiter au mieux de toute la place possible, dans un style élégant et intelligent: les deux miroirs contiennent une bibliothèque et donnent vie à Luxor, une pyramide multifonction, où le miroir a un reflet bronze.

Exploiting every surface and every space in an elegant and sophisticated way: two mirrors that hold a library and give shape to Luxor, a multitasking pyramid where the mirror takes a bronze shade.



Struttura / Structure / Body: verniciato, verni, coated - Bronzo gofrato M19
Specchio / Miroir / Mirror: vetro, verre, glass - Bronzo liscio G11

MIROIRS / MIRRORS
SPECCHIERE



Poltroncina JOLLY CROSS SOFT
Base / Piétement / Base: verniciato, verni, coated - Bronzo goffrato M19
Seduta / Assise / Seat: pelle, cuir, leather - Testa di moro JP44

| Luxor_mirror





| Glory

mirror

design **Andrea Lucatello**

Glory è molto più di una specchiera, dotata di un'ampia cornice in un gioco di ceramica e specchi, diviene un elemento scultoreo capace di combinarsi con moduli a giorno o madie. Posizionato in orizzontale, verticale o in appoggio a terra assolve a molteplici funzioni all'interno di spazi abitativi moderni o negozi informali dalla nota glamour.

Glory est beaucoup plus qu'un miroir: son grand cadre en céramique incrusté devient un élément sculptural capable de se combiner avec des modules ouverts ou des bahuts. Positionné horizontalement, verticalement ou appuyée sur le sol, il remplit de multiples fonctions dans des espaces living modernes ou dans des magasins informels avec une note glamour.

Glory is much more than a mirror: equipped with a large framework with ceramic and glass, it becomes a sculptural element capable of combine itself with consoles or sideboards. Horizontally, vertically or located on the ground located it fulfils multiple functions in the living areas or shop with a touch of glamour.



MIROIRS / MIRRORS
SPECCHIERE



Specchio / Miroir / Mirror: *ceramica, céramique, ceramic - Pietra di Savoia Antracite K11*

Poltroncina MINNIE SWIVEL SOFT

Base / Piétement / Base: *verniciato, verni, coated - Tortora opaco M12*

Seduta / Assise / Seat: *pelle, cuir, leather - Camoscio JP36*

Profilo / Profile / Piping: *ecopelle, eco-cuir, eco-leather - Grigio pietra EB10*



Specchio / Miroir / Mirror: ceramica, céramique, ceramic - Pietra di Savoia Perla K12 / Pietra di Savoia Antracite K11

Sedia JOLLY

Gambe e seduta / Pieds et assise / Legs and seat: tessuto, tissu, fabric Karina - Grigio platino TK24

Profilo / Profile / Piping: ecopelle, eco-cuir, eco-leather - Testa di moro EB57



| **Glory_mirror**





Florence

mirror

design_Andrea Lucatello

In pochi centimetri di spessore Florence concentra tutta la sua capacità di ampliare lo spazio. L'insero laccato interrompe gradevolmente le sue linee essenziali, amplificando la leggerezza che continua ad essere la caratteristica principale di questa specchiera.

Florence est la solution parfaite pour augmenter la place disponible, grâce à sa petite épaisseur. L'élément laqué coupe agréablement ses lignes essentielles, en soulignant la légèreté qui caractérise ce miroir.

In a few centimeters thickness Florence focuses its capacity of widening space. The lacquered insert pleasantly interrupts its essential lines, amplifying the lightness, which remains the main characteristic of this mirror.

Struttura / Structure / Body:
laccata, laqué, lacquered -
Sabbia L70





| DIMENSIONI
DIMENSIONES
DIMENSIONS

| Specchiere

miroirs, mirrors

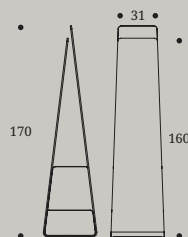

Luxor mirror
page 294

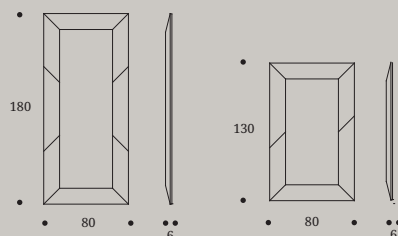

Glory mirror
page 298

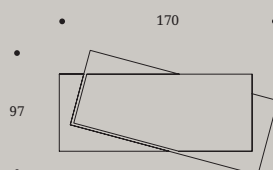

Florence mirror
page 304

*BIBLIOTHÈQUES
/ BOOKCASES*

COM
PAR^I
ITALIAN DESIGN

| LIBRERIE

| Infinity

bookcase

design_Com.p.ar

Pochi elementi essenziali definiscono gli ampi spazi della libreria Infinity. Le colonne in legno sostengono le sottili ed eteree mensole in vetro trasparente, con un effetto d'insieme leggero e luminoso.

La bibliothèque Infinity a peu d'éléments définissants les amples espaces de ce produit. Les colonnes en bois soutiennent les fines étagères en verre, pour un résultat très élégant.

A few essential elements define the wide spaces of the Infinity library. The wooden columns sustain the thin and heavenly shelves in transparent glass with an overall effect of lightness.



Struttura / Structure / Body: legno impiallacciato, bois placage, veneered wood -
Rovere fumé W07, Noce canaletto W10
Mensole / Étagères / Shelves: vetro, verre, glass - Trasparente extrachiario G07

Poltroncina JOLLY

Gambe e seduta / Pieds et assise / Legs and seat: tessuto, tissu, fabric Karina - Verde acido TK09
Profilo / Profile / Piping: ecopelle, eco-cuir, eco-leather - Testa di moro EB57

BIBLIOTHÈQUES / BOOKCASE

LIBRERIE

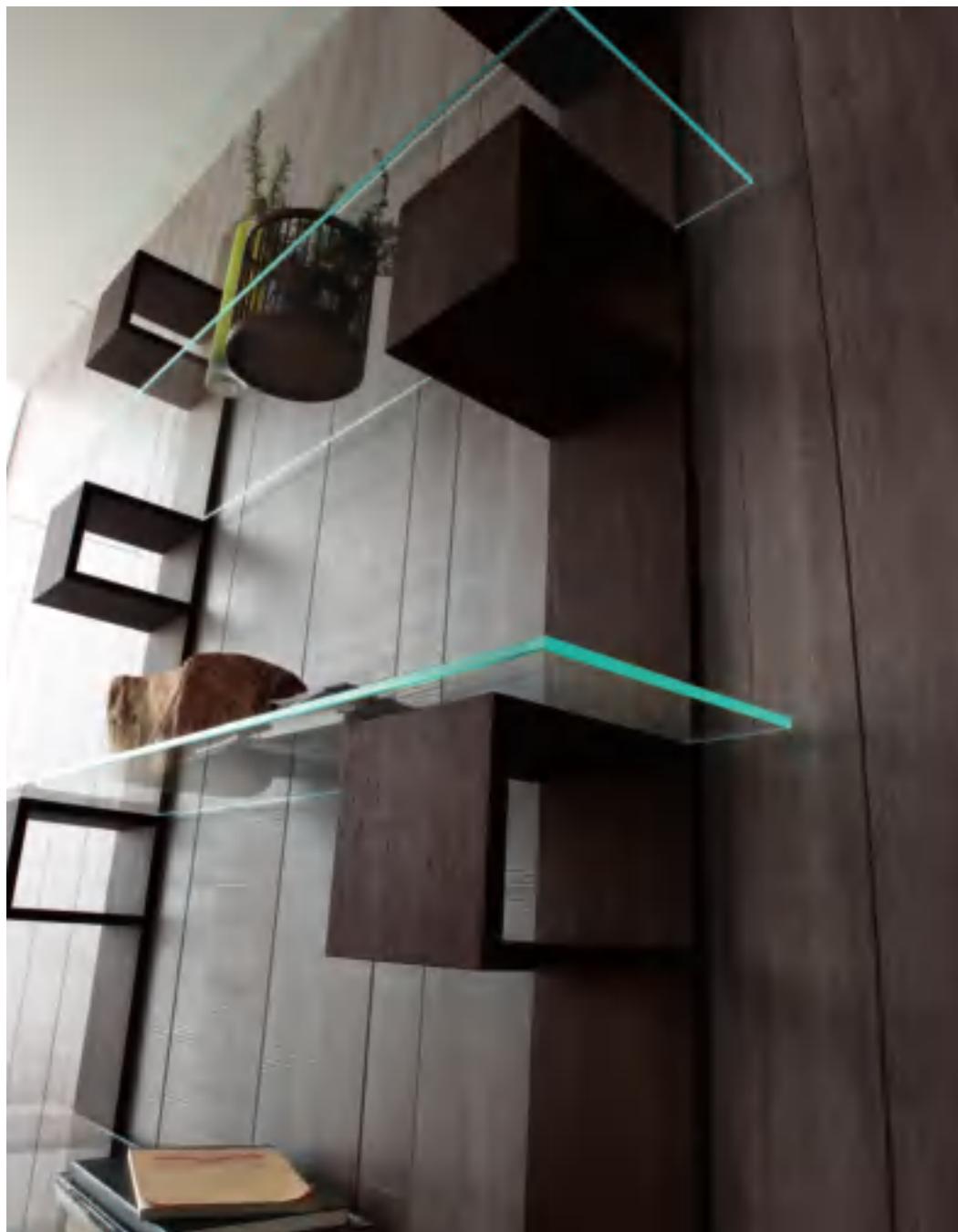

Struttura / Structure / Body: legno impiallacciato, bois placage, veneered wood - Rovere fumé W07





| Step

bookcase

design_Com.p.ar

Una libreria dal minimo ingombro e dalla grande portata, Step è il complemento che garantisce la massima funzionalità in poco spazio. Gli spessori esili dei suoi elementi si rivestono delle finiture verniciate in tutti i colori a catalogo.

Une bibliothèque petite mais de grande capacité au même temps, Step est un complément qui assure la pleine fonctionnalité. Les petites épaisseurs de ces éléments sont disponibles dans plusieurs vernis couleurs.

Step is a library with reduced volume but big capacity. It is the accessory that guarantees the maximum functionality in a small space. The low thickness of its elements dress up with coated finishes in every colour of the catalogue.



BIBLIOTHÈQUES / BOOKCASE

LIBRERIE



Struttura / Structure / Body: verniciato, verni, coated - Bronzo goffrato M19, Rosso vino goffrato M23

| Step_bookcase







| **Plane**
bookcase

| design_STUDIOF+B

Una finestra di colore nella parete: Plane è la libreria a pannello con cinque ripiani che, con spirito vivace e brillante, porta una nota di buonumore nell'aria. In metallo verniciato si fissa alla parete e ne lascia scorgere alcune porzioni.

Une fenêtre de couleur au mur: Plane est la bibliothèque avec 5 étagères qui mettent toujours de bonne humeur. On peut la fixer au mur, en laissant apercevoir de petits morceaux.

A coloured window in the wall: Plane is a library with five shelves, with lively and brilliant spirit and that brings good mood to your day. The painted metal is fixed to the wall, leaving glimpse some portions of it.

Struttura / Structure / Body: verniciato, verni, coated - Rosso vino goffrato M23







| DIMENSIONI
DIMENSIONES
DIMENSIONS

Librerie

bibliothèques, bookcases

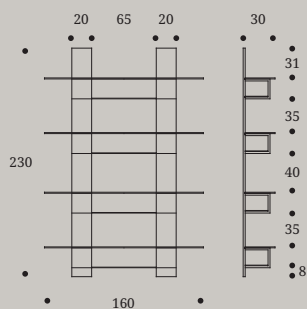

Infinity bookcase
page 310

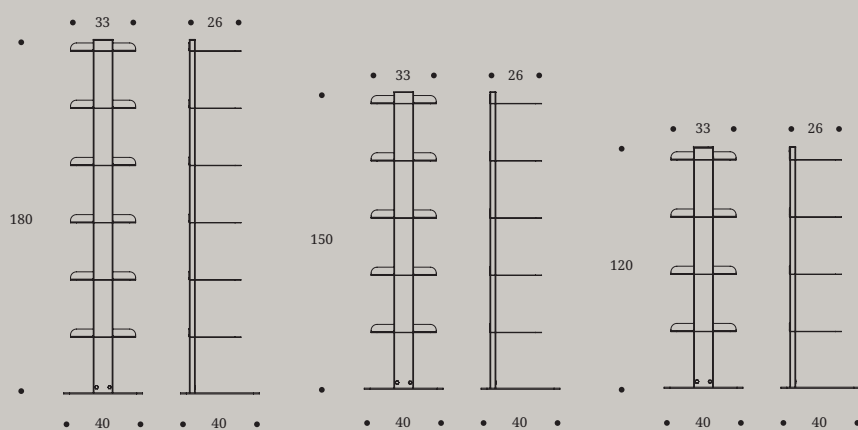

Step bookcase
page 314

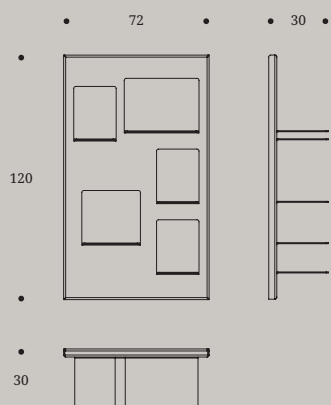

Plane bookcase
page 318

—

*ACCESSOIRES
/ ACCESSORIES*



| ACCESSORI

Charlie

valet stand

Charlie è un oggetto studiato in ogni dettaglio per offrire il massimo comfort di utilizzo. Oltre ad uno spazio dedicato ad ogni capo, dispone di un vano svuota tasche ed un incavo appendi borsa. I momenti preziosi di routine quotidiana saranno così ottimizzati.

design_Riccardo Buscato

Charlie est un produit étudié dans tous les détails, pour donner toujours le meilleur confort. C'est complété par un petit porte-objet et une petite porte sac, pour optimiser et vivre au mieux chaque moment de la journée.

Charlie is an accessory that has been studied in every detail to offer the maximum usage comfort. In addition to a space dedicated to every dress, it is endowed with a coin try space and a hollow for hanging bags. The precious moments of daily routine will thus be optimized.



Struttura / Structure / Body: verniciato, verni, coated - Grafite gofrato M11

Particolari / Détails / Details: legno massiccio, bois massif, solid wood - Frassino naturale W54

ACCESSOIRES / ACCESSORIES

ACCESSORI



| **Charlie**_valet stand





| Kari

clothes stand

design_Studio SV

Come una fontana ghiacciata le linee di Kari si stagliano in una verticalità interrotta da un accenno di curva. Il rivestimento è in cuoio rigenerato, abbinato al metallo cromo dei dettagli.

Les formes de Kari rappellent une fontaine glacée, grâce à sa verticalité et ses courbes. Le revêtement est en cuir régénéré, assorti aux détails en métal chromé.

Like an ice fountain, the lines of Kari stand out vertically. The coating is made of regenerated leather matched to the chromed metal of the details.



Struttura / Structure / Body: cuoio rigenerato, cuir régénéré, regenerated leather - Bianco RC01

| Shark

clothes stand

design_Pierpaolo Zanchin

Composto interamente in polietilene, l'appendiabiti Shark si presenta come un pezzo unico, i cui incavi disposti a varie altezze accolgono comodamente i capi.

Le portemanteau Shark est entièrement en polyéthylène: ses cavités à différentes hauteurs sont parfaites pour ranger tous les vêtements.

The coat hanger Shark is entirely made of polyethylene and presents itself like an icon, whose hollows comfortably host your clothing.



Struttura / Structure / Body: polietilene, polyéthylène, polyethylene - Bianco Z01, Tortora Z03

| Ombo

umbrella stand

Un oggetto dalla semplice funzione valorizzato dal design originale: il portaombrelli Ombo è disponibile in tutte le tinte del cuoio rigenerato, ed è arricchito dal dettaglio delle cuciture a vista.

design_Arter&Citton

Un objet simple et au design original: le porte-parapluies Ombo est disponible dans toutes les couleurs de cuir régénéré, avec les coutures à vue.

An accessory with simple functionality, enhanced by the original design: the umbrella stand Ombo is available with all colour of regenerated leather and is enriched by the stitchings.



Struttura / Structure / Body: cuoio rigenerato, cuir régénéré, regenerated leather - Bianco RC01, Testa di moro RC08, Nero RC10

| Snake

magazine rack

Il portariviste Snake dalla forma bizzarra arreda con un delicato tocco di fantasia ogni ambiente, nelle colorazioni neutre del polietilene.

design_**Com.p.ar**

Le porte-revues aux formes bizarres est parfait pour tous les styles de déco, dans les couleurs neutres en polyéthylène.

Snake magazine rack with its bizarre shape furnishes every space with a delicate touch of fantasy in its neutral polyethylene colourings.



Struttura / Structure / Body: polietilene, polyéthylène, polyethylene - Bianco Z01

Accessori

accessoires, accessories

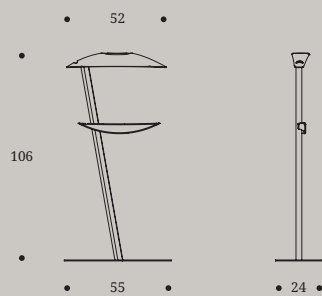

_Charlie valet stand
page 326

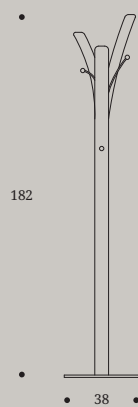

_Kari clothes stand
page 330

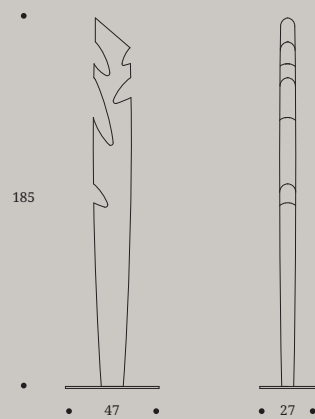

_Shark clothes stand
page 331

| Accessori

accessoires, accessories

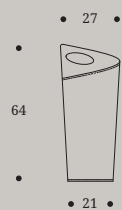

_Ombo umbrella stand
page 332

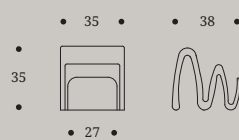

_Snake magazine rack
page 333

MATERIALI
MATÉRIAUX
MATERIALS

| **LEGNO IMPIALLACCIATO**
__BOIS PLACAGE
__VENEERED WOOD

- W02 *Rovere grigio*
- W03 *Rovere tabacco*
- W04 *Rovere nodato*
- W07 *Rovere fumé*
- W10 *Noce canaletto*



W02



W03



W04

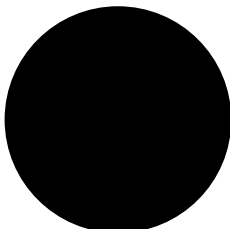

W07



W10

| **LEGNO MASSICCIO**
__BOIS MASSIF
__SOLID WOOD

- W52 *Frassino grigio*
- W53 *Frassino tabacco*
- W54 *Frassino naturale*
- W57 *Frassino fumé*
- W60 *Frassino canaletto*

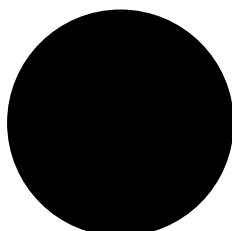

W52



W53



W54



W57



W60

| **CERAMICA**
__CÉRAMIQUE
__CERAMIC

- K01 *Fokos Sale*
- K02 *Fokos Terra*
- K03 *Fokos Piombo*
- K04 *Noir Desir Lucido*
- K05 *Bianco Statuario Venato Lucido*
- K06 *Diamond Cream Lucido*
- K07 *Pietra Grey Lucida*
- K09 *Oxide Nero*
- K10 *Oxide Bianco*
- K11 *Pietra di Savoia Antracite*
- K12 *Pietra di Savoia Perla*
- K13 *Calacatta Gold Lucido*
- K14 *Emperador Lucido*
- K15 *Noir Desir Opaco*
- K16 *Pietra Grey Opaco*
- K17 *Calacatta Gold Opaco*
- K18 *Bianco Statuario Venato Opaco*
- K19 *Diamond Cream Opaco*
- K20 *Emperador Opaco*

LAMINAM
SUPERIOR NATURAL SURFACES

| **VETRO**
__VERRE
__GLASS

- G04 *Bianco acidato*
- G05 *Tortora acidato*
- G07 *Trasparente extrachiario*
- G10 *Cenere acidato*
- G11 *Bronzo liscio*
- G12 *Fumé liscio*
- G13 *Bronzo bocciardato*
- G14 *Fumé bocciardato*

COM
PARI
ITALIAN DESIGN



K01



K02



K03



K04



K05



K06

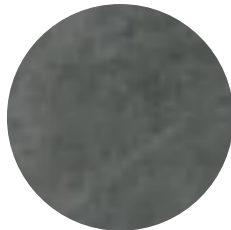

K07

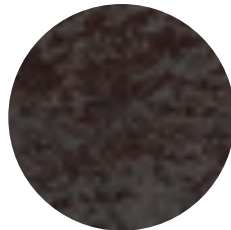

K09



K10



K11



K12



K13



K14

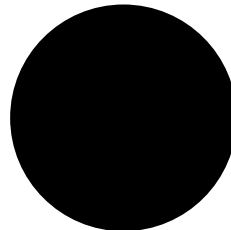

K15

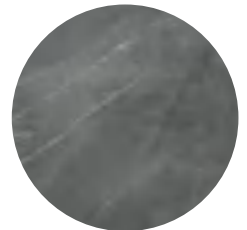

K16



K17

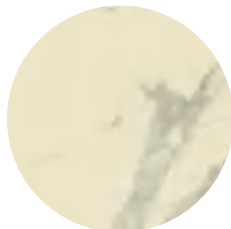

K18



K19



K20

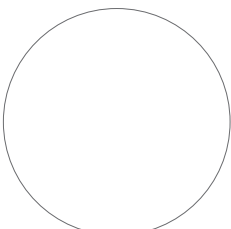

G04

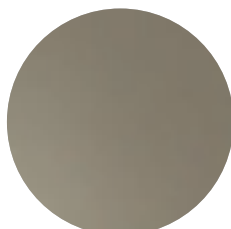

G05

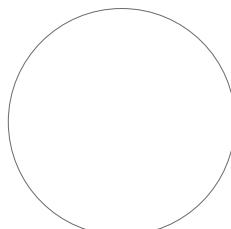

G07

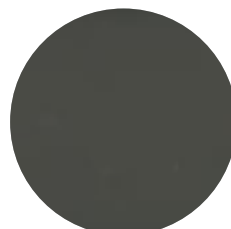

G10

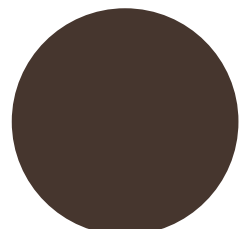

G11

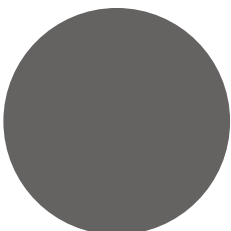

G12



G13

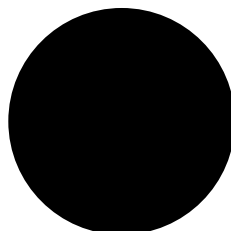

G14

**MATERIALI
MATÉRIAUX
MATERIALS**

**| LACCATO
_LAQUÉE
_LACQUERED**

- L05 *Antracite metallizzato*
- L51 *Bianco luce*
- L70 *Sabbia*
- L71 *Bronzo metallizzato*
- L72 *Grigio cenere*

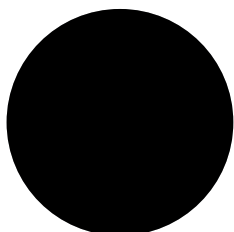

L05

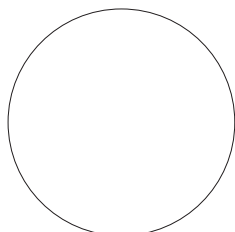

L51

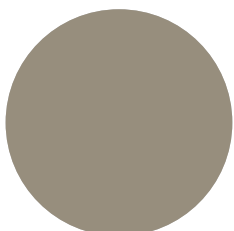

L70

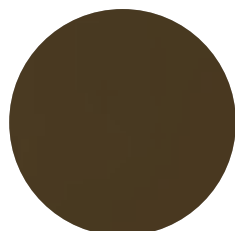

L71

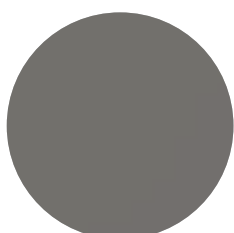

L72

**| METALLO
_MÉTAL VERNI ÉPOXY
_ÉPOXY COATED METAL**

- M05 *Cromo lucido*
- M11 *Verniciato grafite goffrato*
- M12 *Verniciato tortora opaco*
- M19 *Verniciato bronzo goffrato*
- M20 *Verniciato nero goffrato*
- M23 *Verniciato rosso vino goffrato*
- M24 *Verniciato bianco goffrato*
- M28 *Verniciato lava opaco*

**| POLIURETANO RIGIDO VERNICIATO
_POLYURÉTHANE RIGIDE PEINT
_PAINTED RIGID POLYURETHANE**

- U01 *Titanio + bronzo metallizzato*
- U02 *Blu + antracite metallizzato*
- U03 *Bronzo metallizzato*
- U04 *Antracite metallizzato*

**| POLIURETANO MORBIDO
_POLYURÉTHANE SOUPLE
_SOFT POLYURETHANE**

- S01 *Bianco*
- S02 *Nero*
- S03 *Rosso*
- S04 *Grigio*

**| POLIETILENE
_POLYÉTHYLÈNE
_POLYETHYLENE**

- Z01 *Bianco*
- Z02 *Nero*
- Z03 *Tortora*
- Z05 *Verde*
- Z07 *Azzurro*
- Z09 *Rosa*

COM
PARI
ITALIAN DESIGN



M05

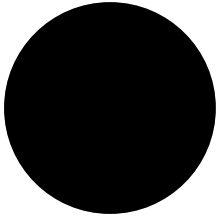

M11

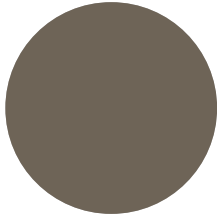

M12

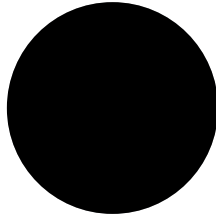

M19

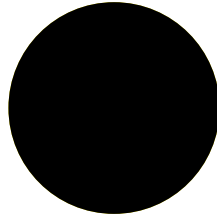

M20



M23



M24

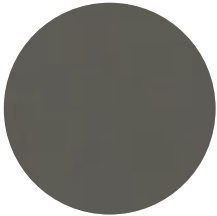

M28



Titanio

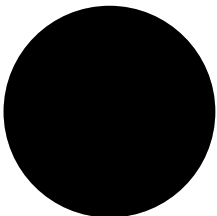

Bronzo



Blu

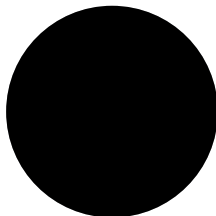

Antracite

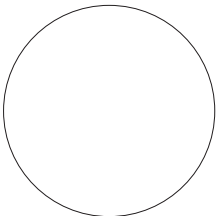

S01

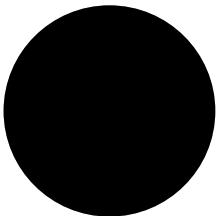

S02

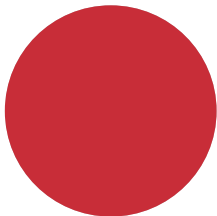

S03

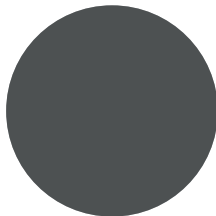

S04

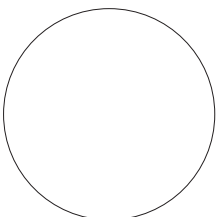

Z01

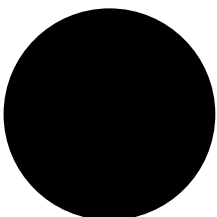

Z02

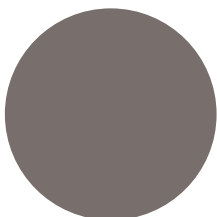

Z03

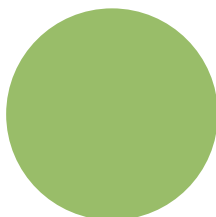

Z05

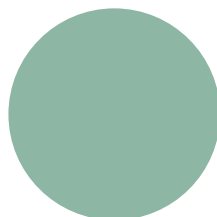

Z07

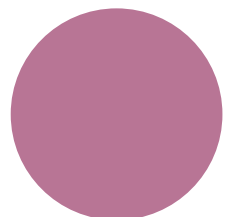

Z09

**MATERIALI
MATÉRIAUX
MATERIALS**

**| CUOIO RIGENERATO
_CUIR RÉGÉNÉRÉ
_REGENERATED LEATHER**

RC01 *Bianco*
RC08 *Testa di moro*
RC10 *Nero*

**| ECOCUOIO
_ECO-CUIR ÉPAIS
_THICK ECO-LEATHER**

EK01 *Bianco*
EK08 *Testa di moro*
EK11 *Lava*

**| PELLE
_CUIR
_LEATHER**

JP11 *Nero*
JP30 *Bianco*
JP33 *Marrone*
JP34 *Cipria*
JP35 *Grigio perla*
JP36 *Camoscio*
JP38 *Marmotta*
JP39 *Blu*
JP40 *Giallo*
JP41 *Rosso*
JP42 *Porpora*
JP43 *Verde chiaro*
JP44 *Testa di moro*
JP45 *Grigio lava*
JP46 *Antracite*

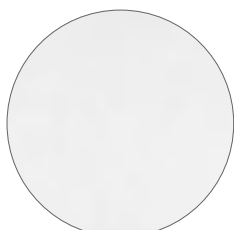

RC01

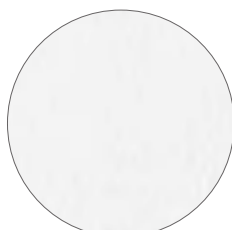

EK01

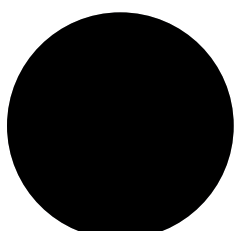

RC08

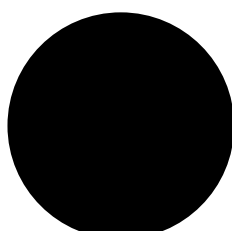

EK08

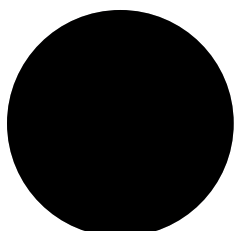

RC10



EK11

**| ECOPELLE NABUK
_ECO-CUIR NABUK
_SOFT ECO-LEATHER**

NB03 *Nocciola*
NB04 *Marrone*
NB07 *Antracite*
NB08 *Bianco*
NB09 *Grigio chiaro*
NB17 *Tortora*

COM
PARI
ITALIAN DESIGN

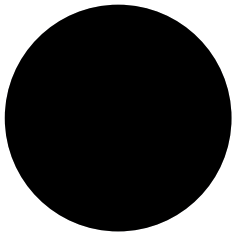

JP11

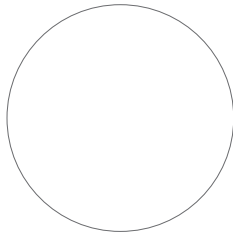

JP30

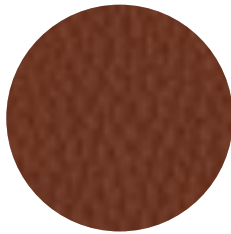

JP33

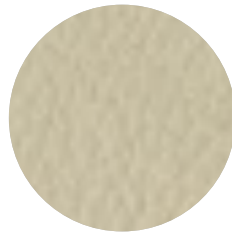

JP34

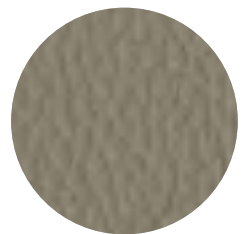

JP35

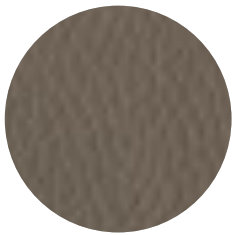

JP36

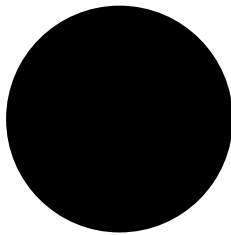

JP38

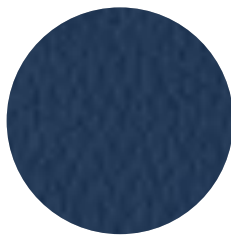

JP39

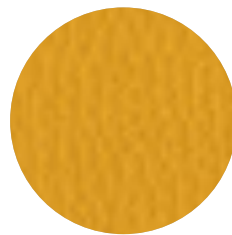

JP40



JP41

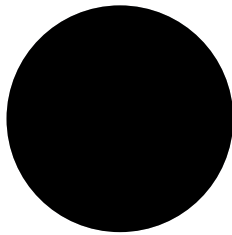

JP42

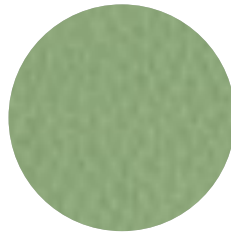

JP43

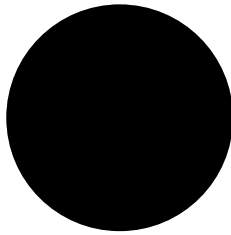

JP44

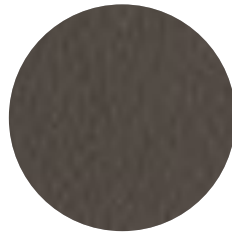

JP45

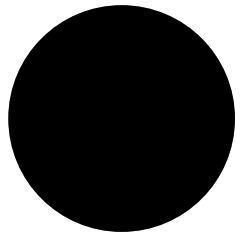

JP46



NB03



NB04

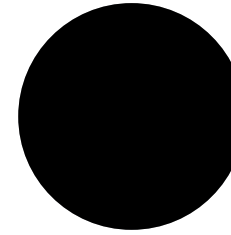

NB07

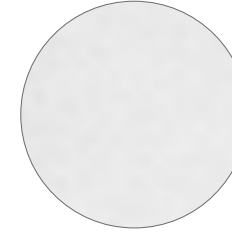

NB08



NB09

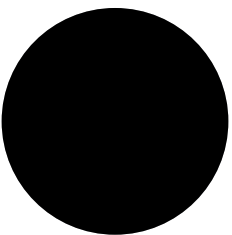

NB17

| ECOPELLE
 _ECO-CUIR
 _ECO-LEATHER

- EB01 *Bianco*
- EB02 *Champagne*
- EB03 *Avorio*
- EB04 *Acciaio*
- EB05 *Grigio chiaro*
- EB06 *Grigio*
- EB07 *Cenere*
- EB08 *Nero*
- EB09 *Tortora*
- EB10 *Grigio pietra*
- EB11 *Beige*
- EB12 *Sabbia*
- EB13 *Kaki*
- EB14 *Argilla*
- EB15 *Fango*
- EB16 *Moka*
- EB17 *Giallo*
- EB18 *Giallo limone*
- EB19 *Giallo fluo*
- EB20 *Verde lime*
- EB21 *Verde mela*
- EB22 *Oliva*
- EB23 *Verde menta*
- EB24 *Verde bosco*
- EB25 *Cipria*
- EB26 *Crema*
- EB27 *Lino*
- EB28 *Vaniglia*
- EB29 *Corda*
- EB30 *Nocciola*
- EB31 *Marrone*
- EB32 *Castagna*
- EB33 *Rosso lampone*
- EB34 *Corallo*
- EB35 *Rosso*
- EB36 *Arancio*
- EB37 *Mou*
- EB38 *Marsala*
- EB39 *Vinaccia*
- EB40 *Bordeaux*
- EB41 *Lilla*
- EB42 *Lavanda*
- EB43 *Malva*
- EB44 *Cannella*
- EB45 *Rosa antico*
- EB46 *Viola orchidea*
- EB47 *Porpora*
- EB48 *Viola*
- EB49 *Turchese*
- EB50 *Azzurro*
- EB51 *Indaco*
- EB52 *Blu genziana*
- EB53 *Blu laguna*
- EB54 *Blu cobalto*
- EB55 *Blu zaffiro*
- EB56 *Blu notte*
- EB57 *Testa di moro*
- EB58 *Fucsia*
- EB59 *Zenzero*

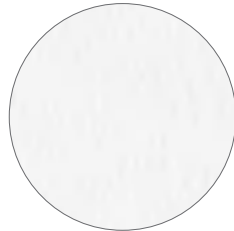

EB01



EB02



EB03



EB04

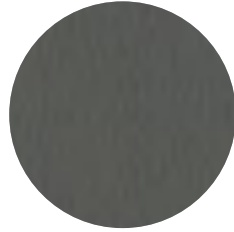

EB06

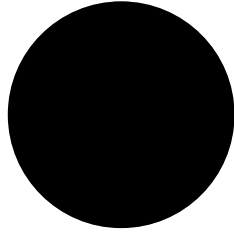

EB07

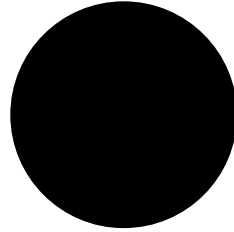

EB08



EB09



EB15

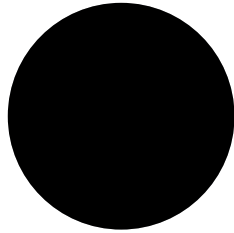

EB16

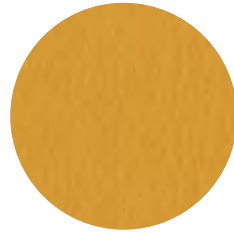

EB17

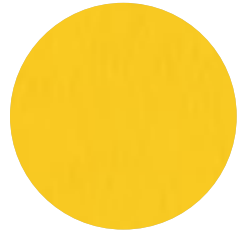

EB18

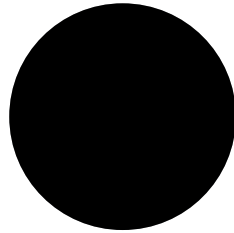

EB24



EB25

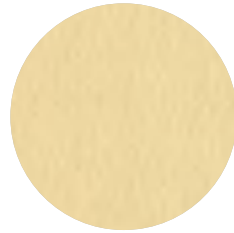

EB26

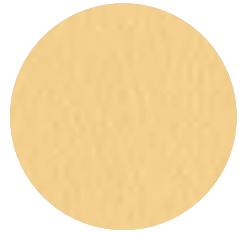

EB27

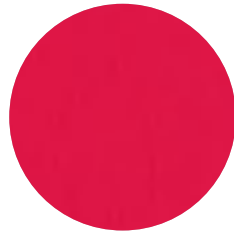

EB33

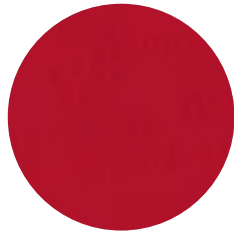

EB34

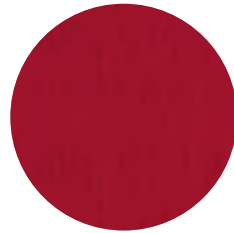

EB35

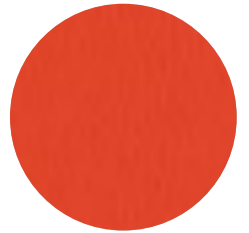

EB36

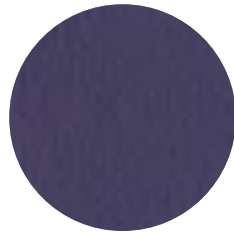

EB42



EB43

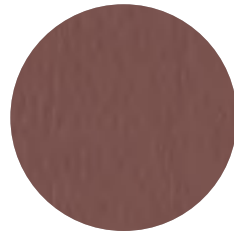

EB44

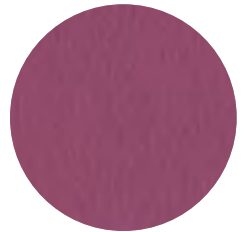

EB45

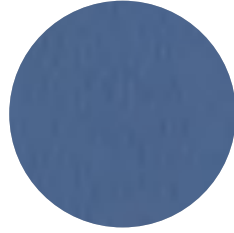

EB51

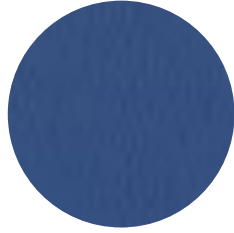

EB52

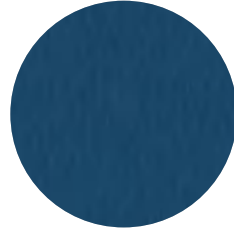

EB53



EB54

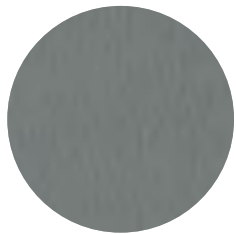

EB05

COM
PARI
ITALIAN DESIGN

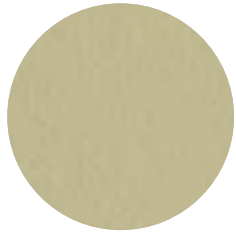

EB10



EB11



EB12



EB13

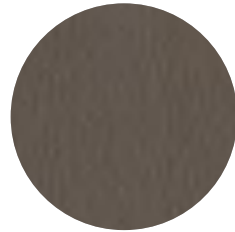

EB14

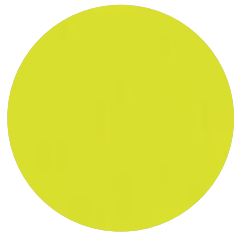

EB19

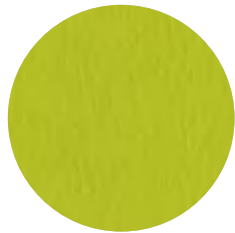

EB20

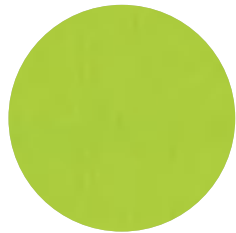

EB21

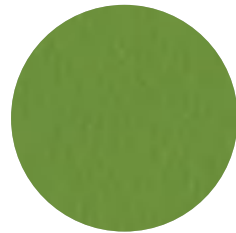

EB22

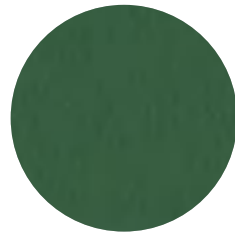

EB23

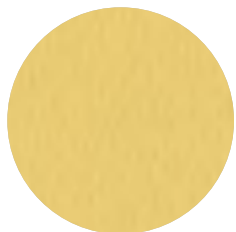

EB28



EB29



EB30

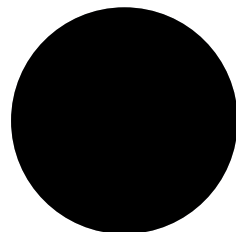

EB31

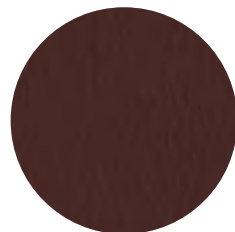

EB32

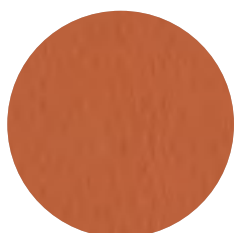

EB37



EB38



EB39



EB40

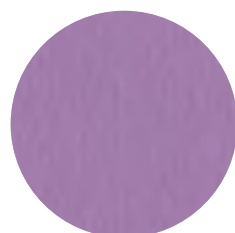

EB41



EB46



EB47



EB48

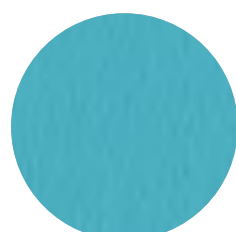

EB49

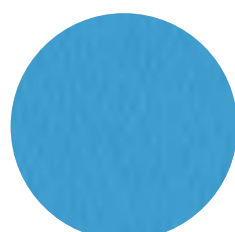

EB50



EB55

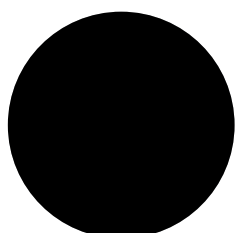

EB56

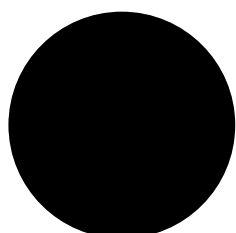

EB57

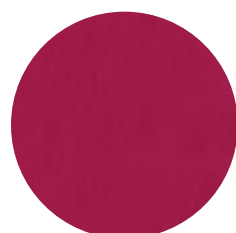

EB58

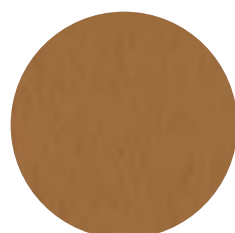

EB59

| TESSUTO KARINA
— TISSU KARINA
— KARINA FABRIC

TK01	<i>Bianco 130</i>
TK02	<i>Tortora 230</i>
TK03	<i>Grigio polvere 330</i>
TK04	<i>Grigio lava 430</i>
TK05	<i>Verde oliva 530</i>
TK06	<i>Testa di moro 630</i>
TK07	<i>Moka 730</i>
TK08	<i>Bordeaux 830</i>
TK09	<i>Verde acido 930</i>
TK10	<i>Giallo ocra 1030</i>
TK11	<i>Arancio 1130</i>
TK12	<i>Rosso 1230</i>
TK13	<i>Amaranto 1330</i>
TK14	<i>Viola 1430</i>
TK15	<i>Porpora 1530</i>
TK16	<i>Rosa antico 1630</i>
TK17	<i>Turchese pastello 1730</i>
TK18	<i>Blu petrolio 1830</i>
TK19	<i>Blu elettrico 1930</i>
TK20	<i>Blu zaffiro 2030</i>
TK21	<i>Blu notte 2130</i>
TK22	<i>Grigio fumo 2230</i>
TK23	<i>Grigio ardesia 2330</i>
TK24	<i>Grigio platino 2430</i>

COM
PARI
ITALIAN DESIGN

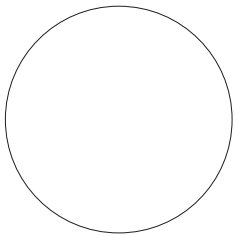

TK01

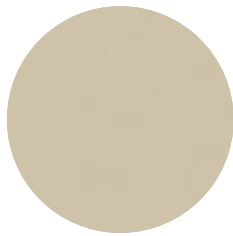

TK02

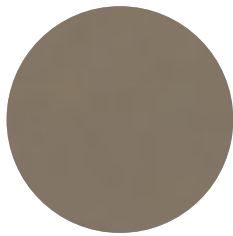

TK03

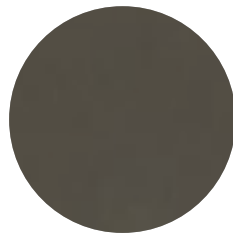

TK04

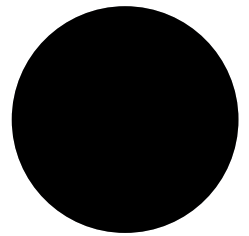

TK05

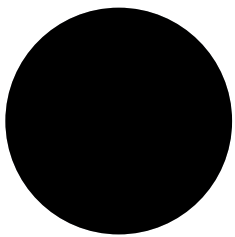

TK06

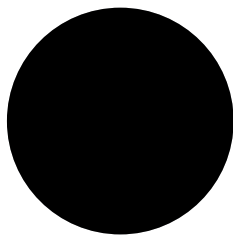

TK07

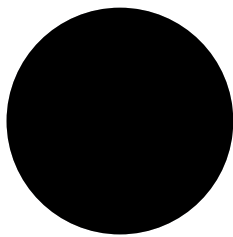

TK08

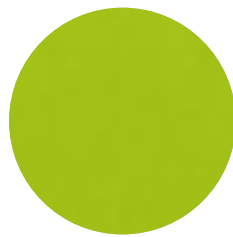

TK09

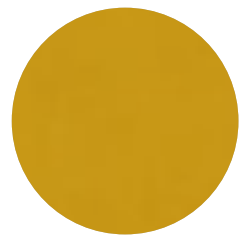

TK10

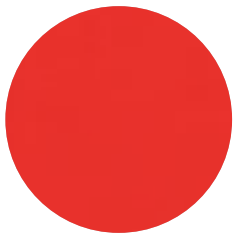

TK11

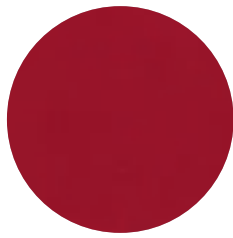

TK12

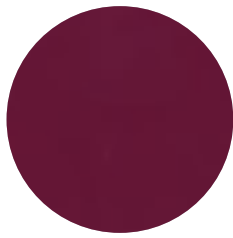

TK13

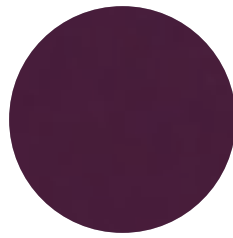

TK14

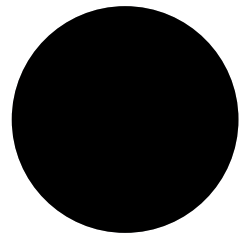

TK15



TK16



TK17

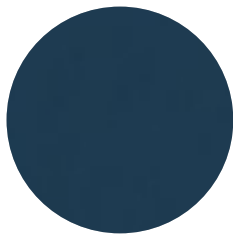

TK18

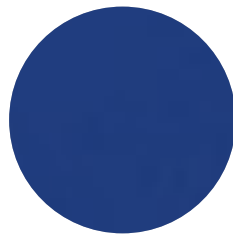

TK19

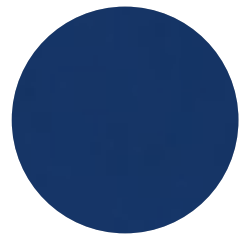

TK20

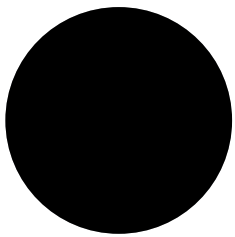

TK21

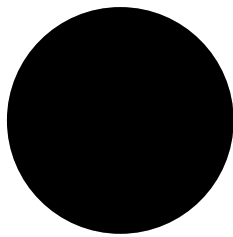

TK22

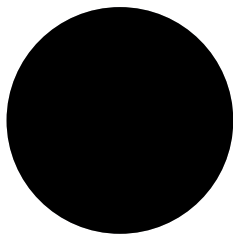

TK23



TK24

| VELLUTO
_VELOURS
_VELVET

- VL01 *Cream*
- VL02 *Beige*
- VL03 *Champagne*
- VL04 *Camel*
- VL05 *Lion*
- VL06 *Teja*
- VL07 *Cuoio*
- VL11 *Ebony*
- VL14 *Taupe*
- VL15 *Chocolate*
- VL16 *Mouse*
- VL19 *Forest*
- VL23 *Lima*
- VL26 *Mud*
- VL30 *Lavanda*
- VL31 *Mostaza*
- VL32 *Brick*
- VL40 *Red rose*
- VL44 *Wine*
- VL45 *Elephant*
- VL47 *Light grey*
- VL51 *Steel*
- VL57 *Petro*
- VL59 *Dark blu*
- VL63 *Deep blu*
- VL64 *Black*
- VL80 *Bordeaux*
- VL81 *Salmon*
- VL82 *Pink*
- VL83 *Violet*
- VL84 *Purple*
- VL85 *Lilac*
- VL86 *Deep red*
- VL87 *Khaki*
- VL88 *Antracite*
- VL89 *Safira*
- VL90 *Light blu*
- VL91 *Turquoise*
- VL92 *Ocean*
- VL93 *Green*



VL01



VL02

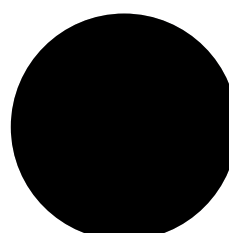

VL11



VL14



VL30



VL31



VL51



VL57



VL82



VL83



VL89

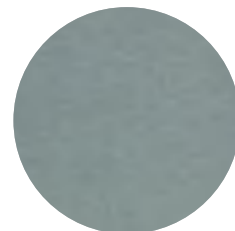

VL90

COM
PARI
ITALIAN DESIGN



VL03



VL04



VL05



VL06



VL07

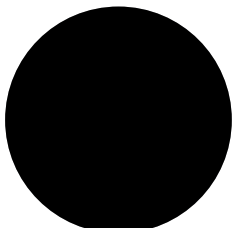

VL15



VL16

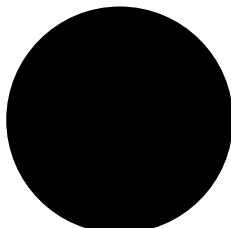

VL19



VL23



VL26



VL32



VL40



VL44



VL45

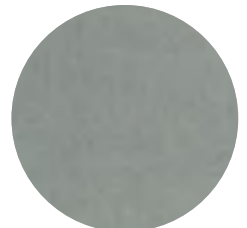

VL47



VL59

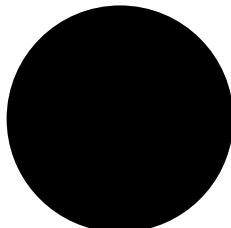

VL63

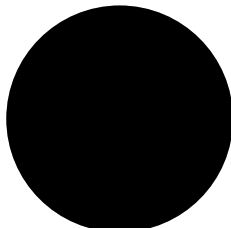

VL64



VL80



VL81

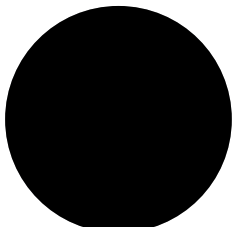

VL84

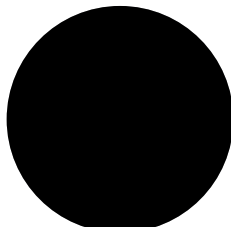

VL85



VL86



VL87



VL88



VL91



VL92

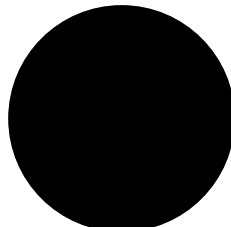

VL93

COM
PAR
ITALIAN DESIGN

Arsenale S.a.s. di Mucelli Angelo & C. | Via dell'Artigianato, 10 -12 | 30024 Musile di Piave, VE Italy
Tel. +39 0421 52468 Fax +39 0421 334007

www.compar-srl.it info@compar-srl.it